

Chaires internationales



de recherche Blaise Pascal

*Financée par l'État et la Région d'Ile de France,
gérée par la Fondation de l'École Normale Supérieure*

The Third Blaise Pascal Lecture
Wednesday 9th December 2009
Ecole Polytechnique
Amphi Faurre

Laser Ion Acceleration

Toshiki Tajima
Blaise Pascal Chair,
Fondation Ecole Normale Supérieure
Institut de Lumière Extrême
and
LMU, MPQ, Garching

Acknowledgments for Advice and Collaboration: G. Mourou, V. Malka, J. Fuchs, C. Labaune, P. Mora, F. Krausz, D. Habs, T. Esirkepov, S. Bulanov, S. Kawanishi, M. Hegelich, Y. Kishimoto, D. Jung, D. Kiefer, X. Yan, A. Henig, R. Hoerlein, S. Steinke, W. Sandner, Y. Fukuda, A. Faenov, M. Tampo, P. Bolton, Y. Ueshima, N. Rostoker, F. Mako, L. Yin, T. Pikuz, A. Pirozgov, M. Borghesi, M. Gross

Advent of collective acceleration (1956)



LMU
www.attoworld.de

CERN Symposium ON HIGH ENERGY ACCELERATORS AND PION PHYSICS

Geneva, 11th - 23rd June 1956

Proceedings

COHERENT PRINCIPLE OF ACCELERATION OF CHARGED PARTICLES

V. I. VEKSLER

Electrophysical Laboratory, Academy of Sciences, Moscow

This paper will include a very brief description of a new principle regarding the acceleration of charged particles.

In all existing accelerators of charged particles, the constant and varying electric field accelerating them is created by a powerful external source, and hence the strength of the field is independent, in the first approximation, of the number of particles which are being accelerated.

In resonance accelerators, the electromagnetic field has to be synchronized with the movement of the particles (this is of particular importance in linear accelerators). Finally, none of the existing methods permits the acceleration of neutral bunches of particles.

A new principle of particle acceleration is set forth below. Its distinctive feature lies in the fact that the particle-accelerating electric field is produced by the interaction of a geometrically small group of accelerated particles with another group of charges, plasma or an electromagnetic wave. This method has a number of important features. It appears, in the first place, that the magnitude of the accelerating field produced by this interaction and acting on each particle depends on the number

Theoretical studies of various aspects of the coherent acceleration method have been made by M. S. Rabinovich, A. A. Kolomenski, B. M. Bolotovskii, L. V. Kovrizhnikh and I. V. Iankov, as well as by A. I. Akhiezer, Ia. Fainberg and their collaborators. The calculations made by these theoretical workers shed light on a number of complicated problems connected with the development of the different variants of this new acceleration principle, and it therefore seems appropriate to describe the new method despite the fact that a great many problems involved still await solution.

1. *Acceleration of charged bunches by means of the medium*

It was pointed out in a paper by Tamm that the loss of energy by particles due to Čerenkov radiation could be reversed, i.e. the medium travelling at a great velocity past charged particles should be able to convey energy to the latter. Up to now, however, no attention has been paid to the possibility of developing an acceleration process of this kind by using a high density electron beam (plasma) as the moving medium. Of course, if a single charge e is

Prehistoric activities (1973-75,...84)



Professor N. Rostoker

Collective ion acceleration by a reflexing electron beam: Model and scaling

F. Mako

Naval Research Laboratory, Washington, D. C. 20375

T. Tajima

Institute for Fusion Studies, University of Texas, Austin, Texas 78712

(Received 21 June 1983; accepted 2 April 1984)

Analytical and numerical calculations are presented for a reflexing electron beam type of collective ion accelerator. These results are then compared to those obtained through experiment. By constraining one free parameter to experimental conditions, the self-similar solution of the ion energy distribution agrees closely with the experimental distribution. Hence the reflexing beam model appears to be a valid model for explaining the experimental data. Simulation shows in addition to the agreement with the experimental ion distribution that synchronization between accelerated ions and electric field is phase unstable. This instability seems to further restrict the maximum ion energy to several times the electron energy.

I. INTRODUCTION

Experiments on collectively accelerating ions utilizing a reflexing intense relativistic electron beam in a plasma have been carried out.^{1,2} These experiments began to reveal sever-

chronous fashion. Thus, energetic ions would be expected. The ion energy would, of course, be bounded above by the ion to electron mass ratio times the initial electron energy; that is, the energy is bounded when the ions reach the initial

Collective acceleration suggested:

Veksler (1956)

(ion energy)~ (M/m)(electron energy)

Many experimental attempts (~'70s):

led to no such amplification

(ion energy)~ (several)x(electron)

Mako-Tajima analysis (1978;1984)

sudden acceleration, ions untrapped,
electrons return, while some run away

→ #1 **gradual acceleration necessary**

→ #2 **electron acceleration** possible
with **trapping** (with Tajima-
Dawson field), **more tolerant** for
sudden process

Path once trodden

Collective acceleration of ions by electron beam

F.Mako / T. Tajima

Ions left out, while electrons shoot backward

→ laser electron acceleration (1979)

→ laser ion acceleration of limited ion mass (2009)

The electric field is

$$\epsilon = \frac{\phi_0}{v_{of}} \frac{5}{36} \left(\frac{6}{\sqrt{3}} - \frac{z}{v_{of}} \right),$$

where the conservation of energy was used as a boundary condition, i.e.,

$$U^2/2 + \psi = 0 \quad \text{at} \quad \zeta = 0.$$

The maximum ion energy can now be obtained by setting $n_i = 0$, i.e.,

$$E_{max} = 6q\phi_0 \quad \text{at} \quad \zeta = 6/\sqrt{3}.$$

In the experiment the diode voltage was 0.8 MV and the ions were doubly ionized helium,⁶ thus the maximum ion energy predicted by theory is

$$E_{max} = 9.6 \text{ MeV}.$$

The experimental result⁶ for the maximum helium ion energy was 9.6 MeV and therefore is in good agreement with the theory.

The ion number as a function of energy is calculated to be

$$N_i(E_i) = \frac{n_0 A}{\beta} \left[\left(\frac{6}{5} \right)^{1/2} - \left(\frac{E_i}{5q\phi_0} \right)^{1/2} \right]^6, \quad (15)$$

where

$$n_0 A = \frac{16 J_{of} A}{5 e} \left(\frac{2m}{e\phi_0} \right)^{1/2},$$

$$\beta = \frac{m}{2} (1/v_{of})^2,$$

$$A = \pi r_0^2, \quad r_0 = \text{electron beam radius,}$$

and

$$v_0 = (q\phi_0/M)^{1/2}.$$

Equation (15) is our main result. The natural logarithm of Eq. (15) is plotted in Fig. 2 along with the experimental

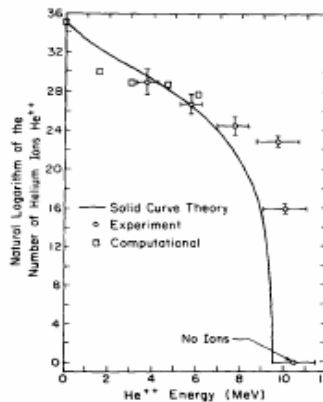

FIG. 2. Comparison between theory, experiment, and simulation, of the natural logarithm of the ion number versus energy.

data. The following experimental values were used: $J_0 = 40$ kA, $\phi_0 = 0.8$ MV, $q = 2e$ (doubly ionized helium), $t = 100$ ns and $r_0 = 2.5$ cm. The agreement between Eq. (15) and the experiment⁶ is reasonable. The relation in Ref. 3 does not provide such a good fit: it has too weak a slope.

III. SCALING AND ACCESSIBILITY OF THE MODEL

In the preceding section, the analysis assumed that a self-similar state could be reached. To address the question of whether a self-similar state can be attained, a detailed analysis of the initial value problem is required. This detailed analysis should include a self-consistent treatment of the dy-

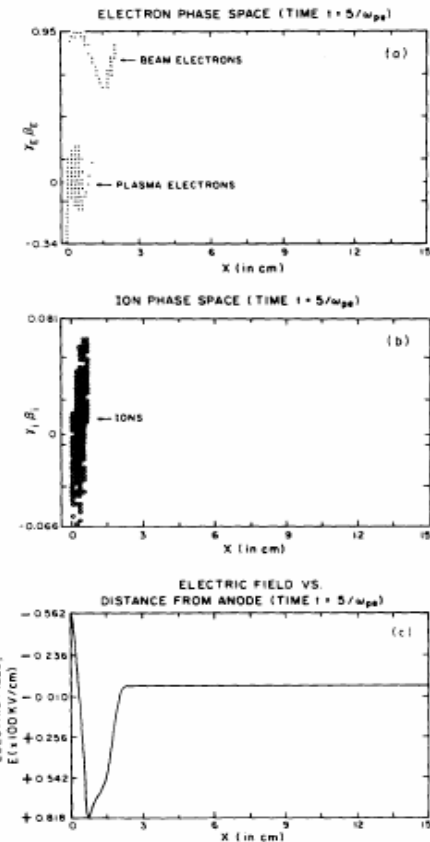

FIG. 3. Simulation phase space at early time $t = 5/\omega_{pe}$. (a) Electron phase space (beam and plasma), (b) ion phase space, (c) electron field versus position.

Example of solid target (ca.1999)

A few hundreds MeV protons and GeV Al are generated by petawatt laser with the Al foil coated with hydrogen.

$$a_{0s} = 69$$

**Al¹⁰⁺(112nm)
culster**

**H⁺ (8nm)
solid**

Laser power	100TW $a_0 = 10$	1PW $a_0 = 30$
energy conversion	21%	31%
ion;	6%	14%
electron;	15%	17%
peak (average) energy		
H ⁺ ;	- (-)	0.4GeV (115MeV)
Al ¹⁰⁺ ;	- (-)	2GeV (430MeV)
electron;	1.5MeV	20MeV

Toward Less Sudden Acceleration (ca.1999)

Energy conversion and acceleration of particles is strongly dependent on the state of the thin foil surface.

$a_0 = 30$

1 PW Laser Intensity;

electron density
Al
solid ; $6 \cdot 10^{23} \text{cm}^{-3}$
(416 n_c)

gas ; $1.5 \cdot 10^{22} \text{cm}^{-3}$
(10.4 n_c)

culster; $3 \cdot 10^{23} \text{cm}^{-3}$
(208 n_c)

H
solid ; $4.6 \cdot 10^{22} \text{cm}^{-3}$
(31.8 n_c)

n_c : cut off density
 $1.4 \cdot 10^{21} \text{cm}^{-3}$

target type $a_{0,s} = 69$	Al ¹⁰⁺ (56nm) solid H ⁺ (28nm) solid	Al ¹⁰⁺ (2240nm) gas H ⁺ (28nm) solid	Al ¹⁰⁺ (112nm) culster H ⁺ (28nm) solid
energy conversion	24%	50%	31%
ion;	8%	4%	14%
electron;	16%	46%	17%
peak (average) energy			
H ⁺ ;	0.4GeV (95MeV)	0.2GeV (58MeV)	0.8GeV (115MeV)
Al ¹⁰⁺ ;	2GeV (500MeV)	1GeV (130MeV)	2GeV (500MeV)
electron;	15MeV	25MeV	20MeV

Patent (Tajima) : submitted from LLNL (2002); granted (2005)

Recent breakthroughs

From **incoherent (or heating)** of electrons

to **Coherent drive** of them



CAIL (Coherent Acceleration of Ions by Laser)

TNSA (Target Normal Sheath Acceleration)

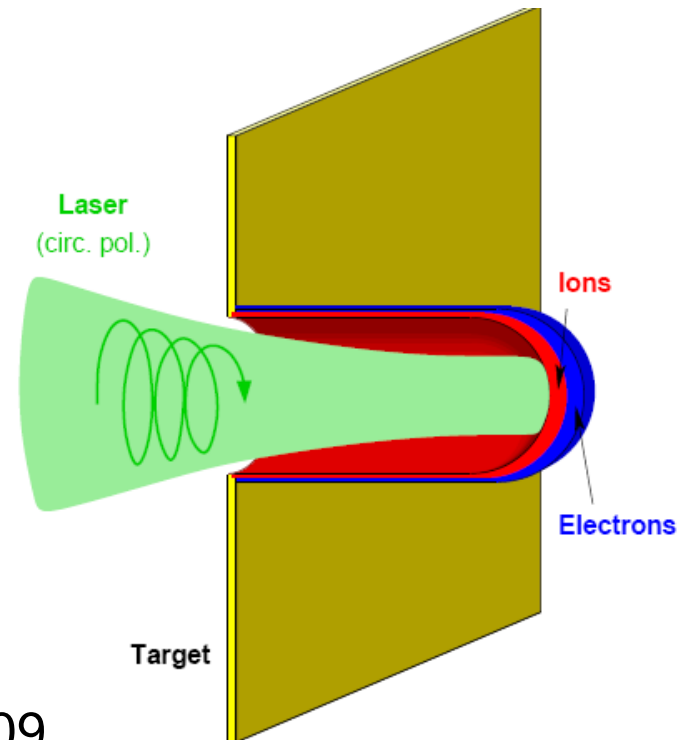
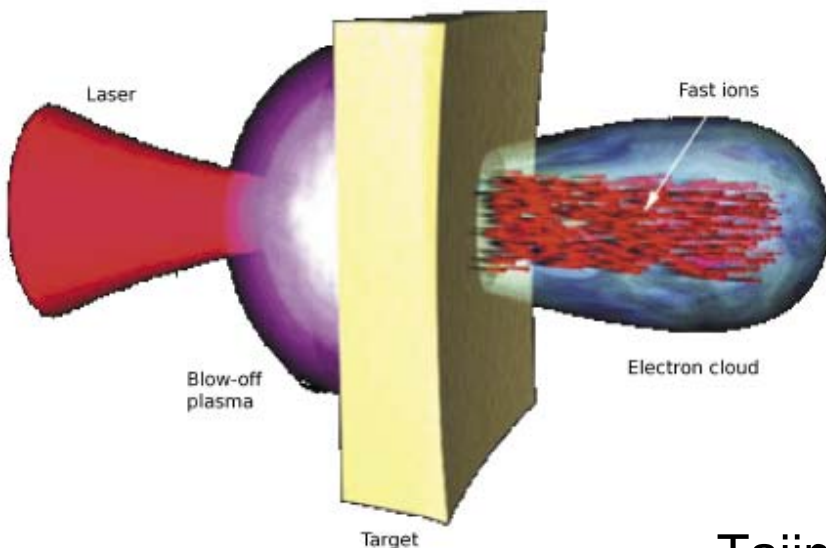

Tajima et al., 2009

Comparison of the phase space dynamics: toward more Adiabatic Acceleration

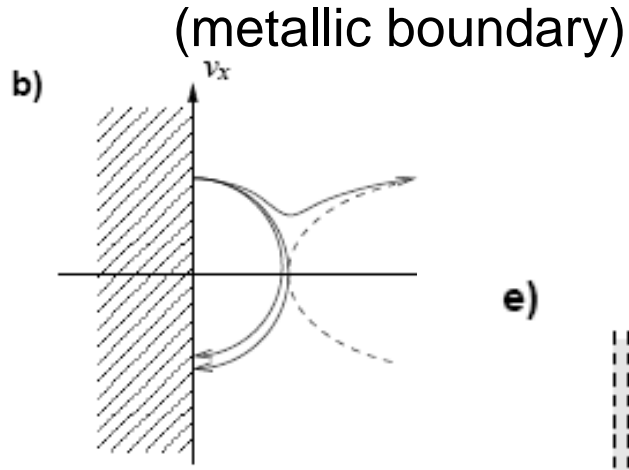
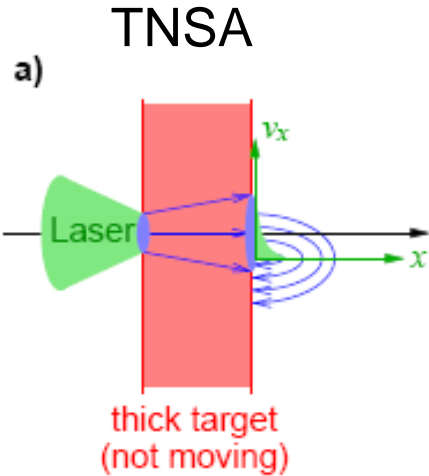

Ion trapping width:

$$v_{tr,ion} \sim c\sqrt{a_0}(m/M)$$

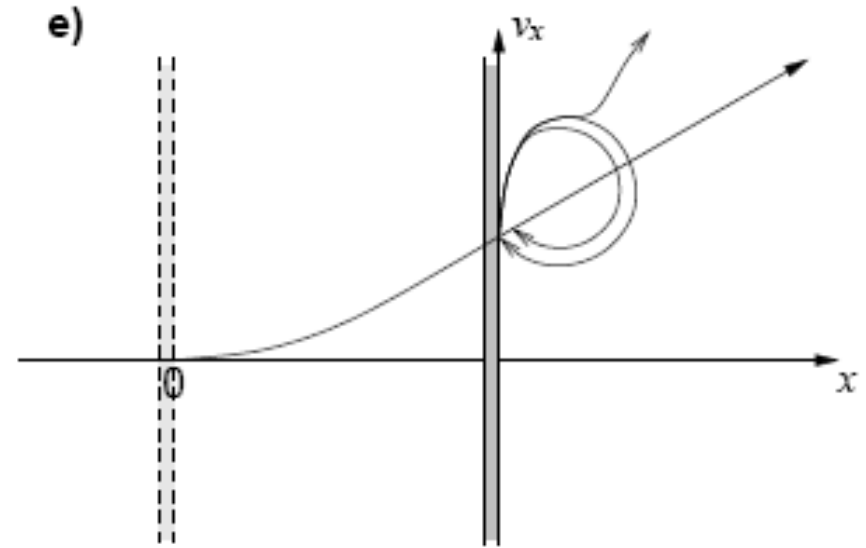
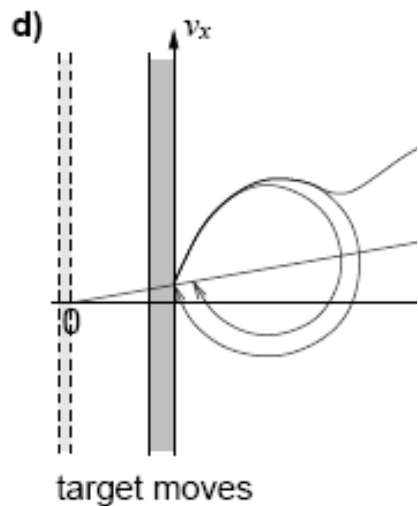
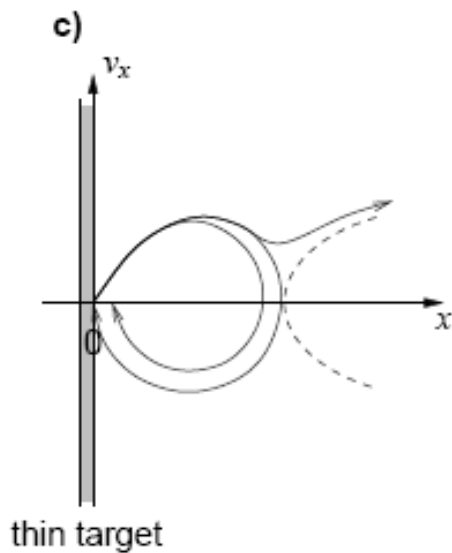

CAIL (with **CP**)

CAIL

Optimal Thickness Scaling

Normalized thickness $\sigma \sim a_0$

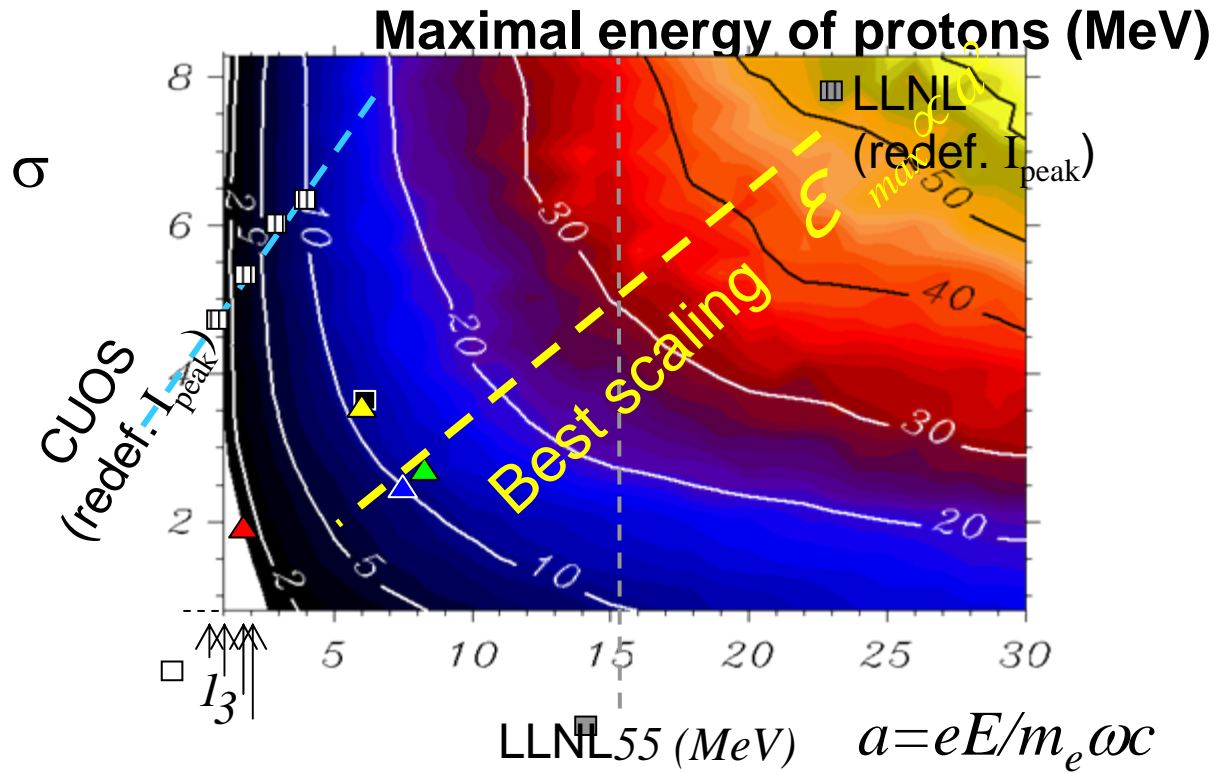

(T.Esirkepov et al.2006)

Recent Experimental Breakthroughs



Leadership
by Dieter Habs

LMU,
MPQ,
Max-Born Institute,
LANL,
RAL,
PMRC



Nanometer target:
DLC

Sharp contrast laser
double plasma
mirrors



More coherent
electron dynamics
in $\sigma \sim a_0$

Recent experiments in **CAIL** Regime

Ultrathin film : $\sigma = a_0$, where $\sigma = d n / \lambda n_c$ ($\xi = \sigma / a_0$)

High laser contrast: not to destroy ultrathin target

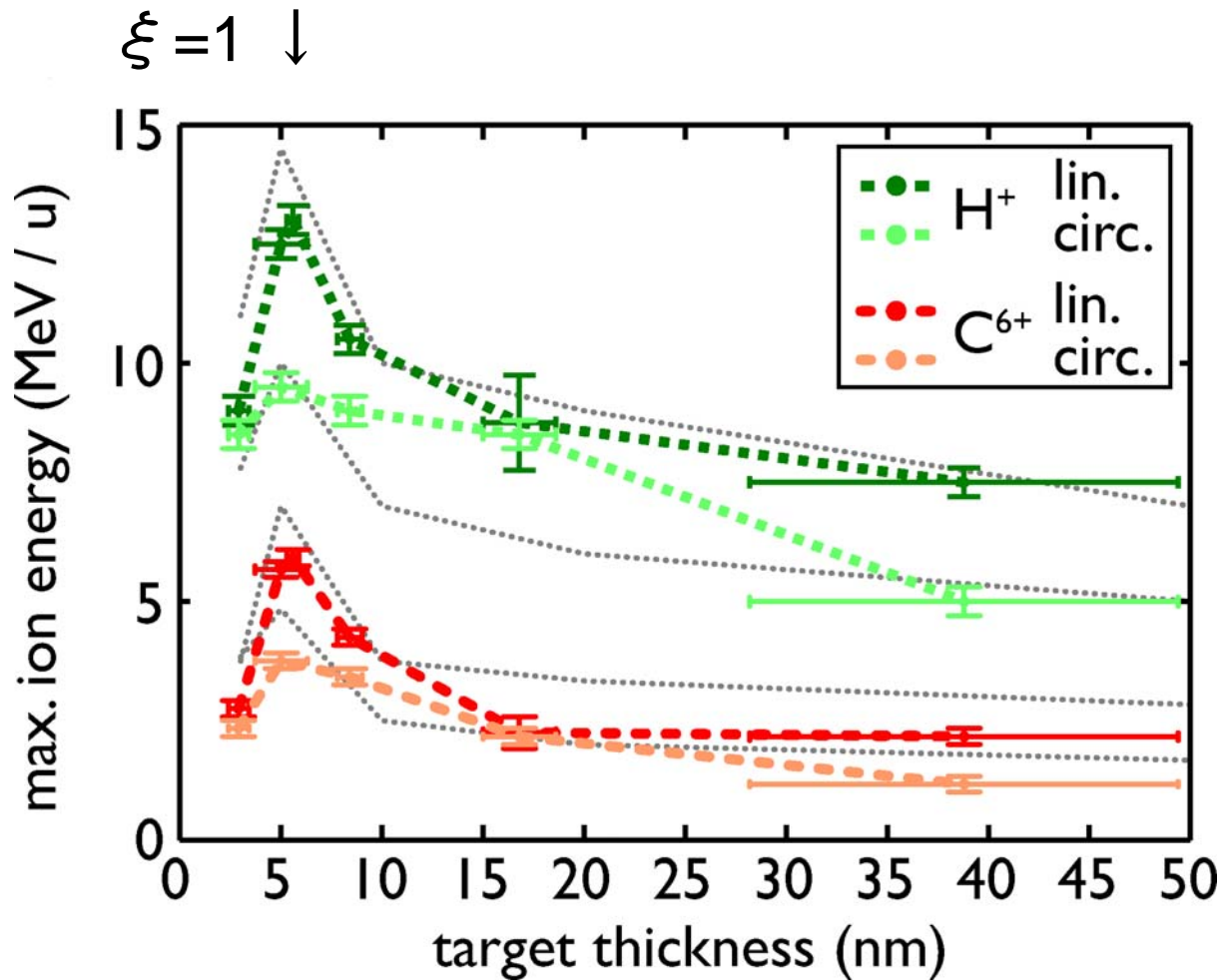

MAP + MBI

(Henig et al, 2009;
Steinke et al.)

Conversion efficiency of laser to ion energy

Two orders of magnitude higher efficiency in **CAIL**

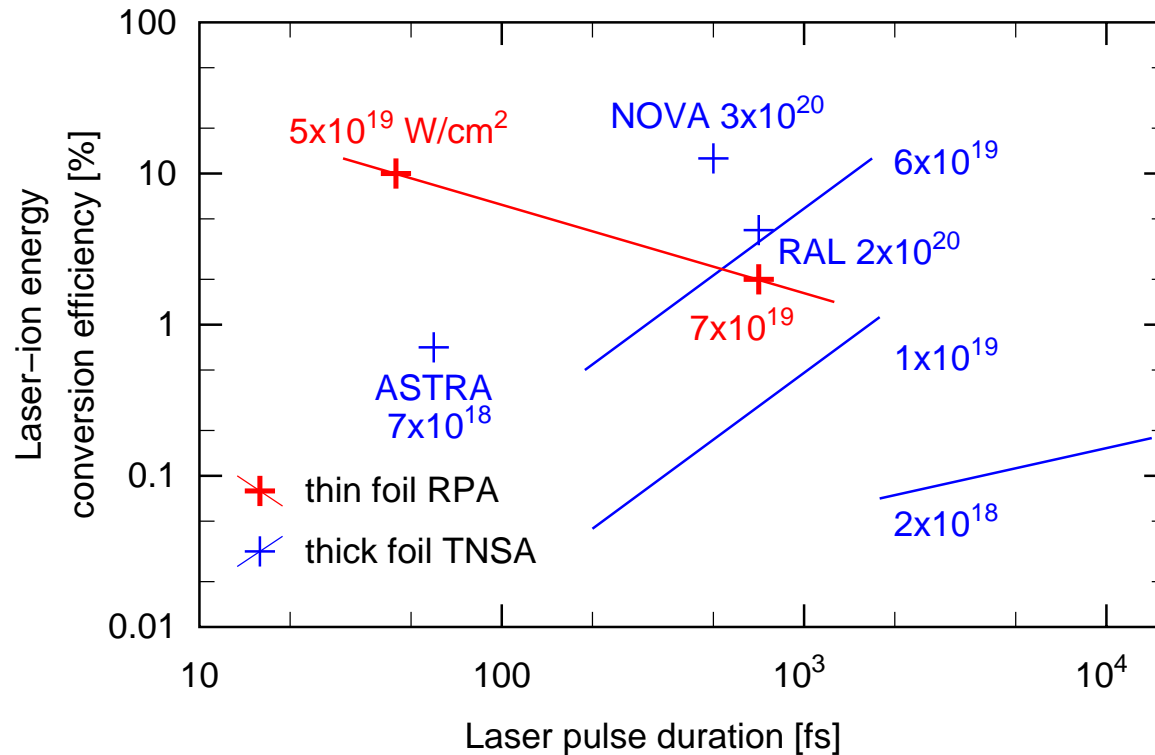

Tajima, et al
(2009)

Conversion efficiency of laser energy to ion energy comparing results from thick targets and the **TNSA** mechanism to measurements with ultra-thin targets in the regime of **CAIL** (red diamonds and line).

Maximum energies of ions

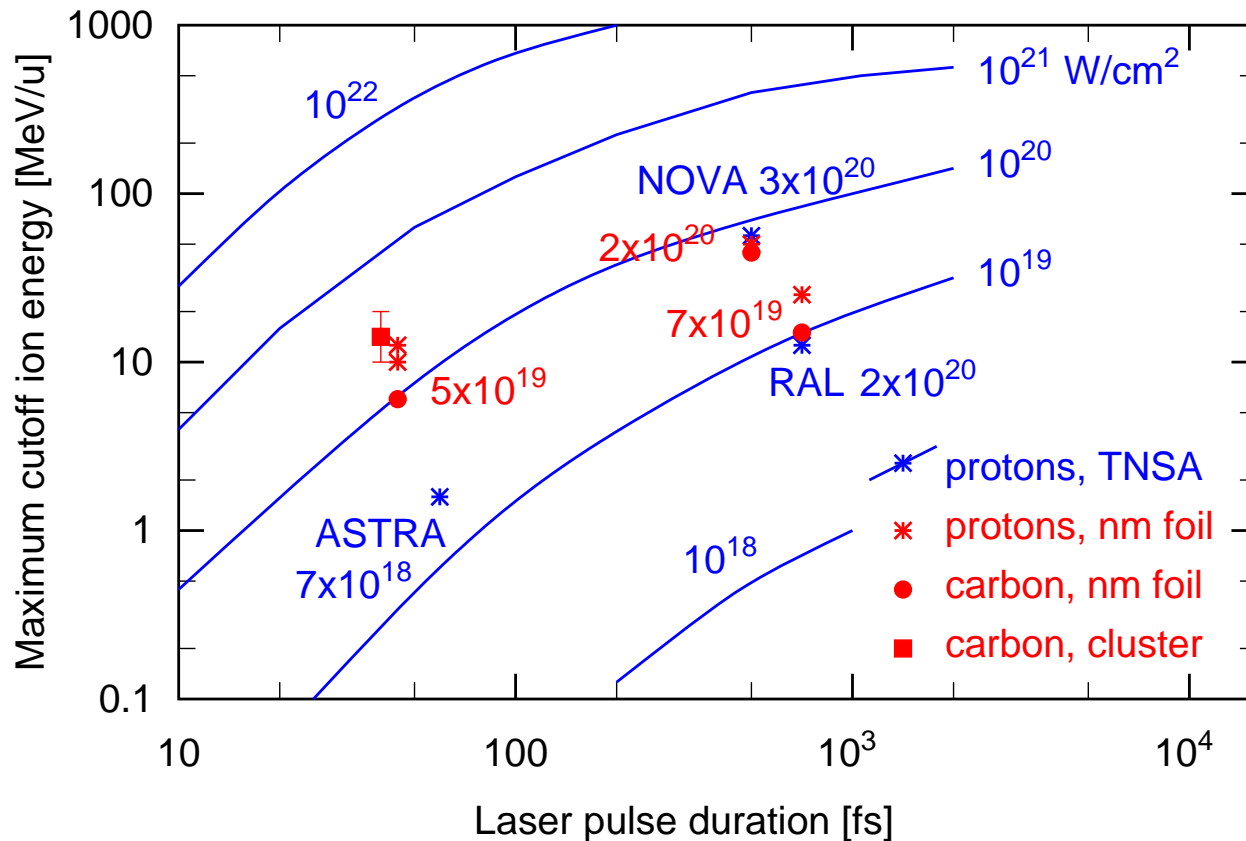

Tajima et al.
(2009)

Fig. 11. Maximum cutoff energies of ions given in MeV/u as a function of laser pulse duration. The energy gain by CAIL experiments is embedded with red dots in the predicted curves of TNSA. Note that in shorter pulses, energies by CAIL are more than an order of magnitude higher than TNSA.

Laser -Thin Foil Interaction

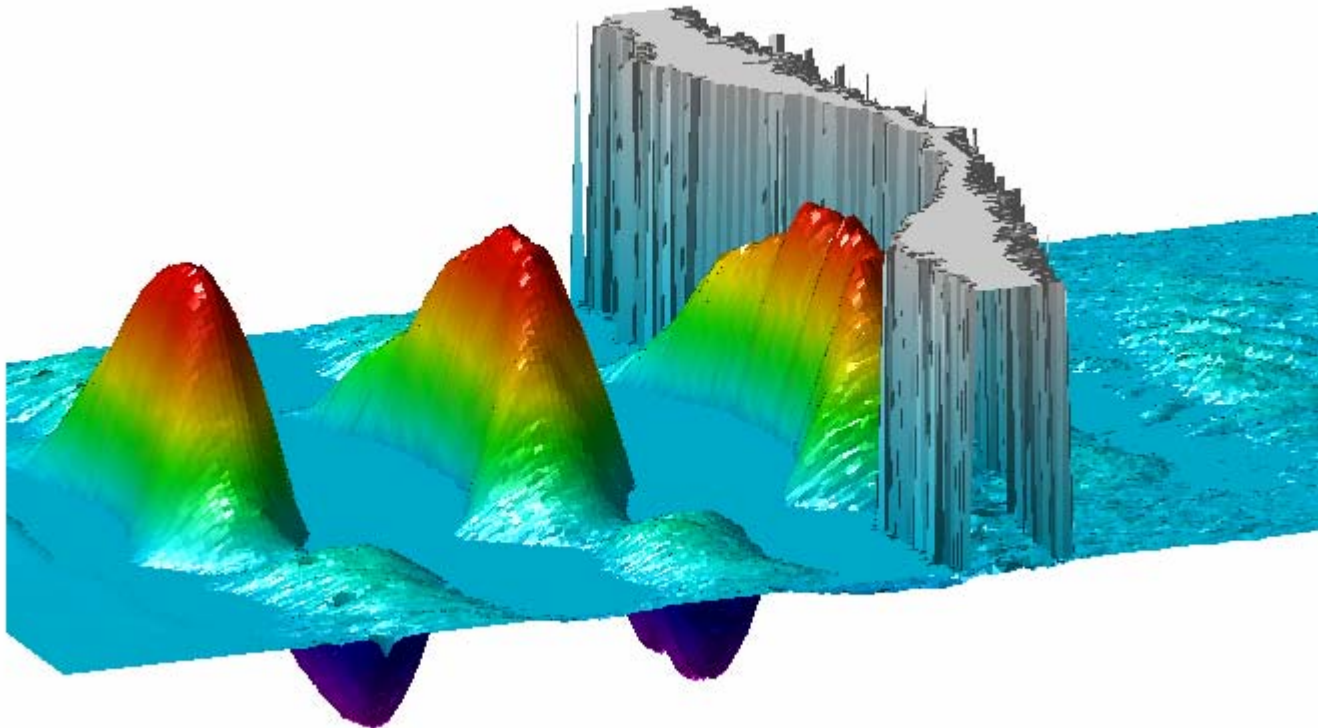

X. Yan et al., 2009

Toward monoenergy spectrum

- **Circularly polarized** laser irradiation
more **adiabatic acceleration** → more **monoenergy**

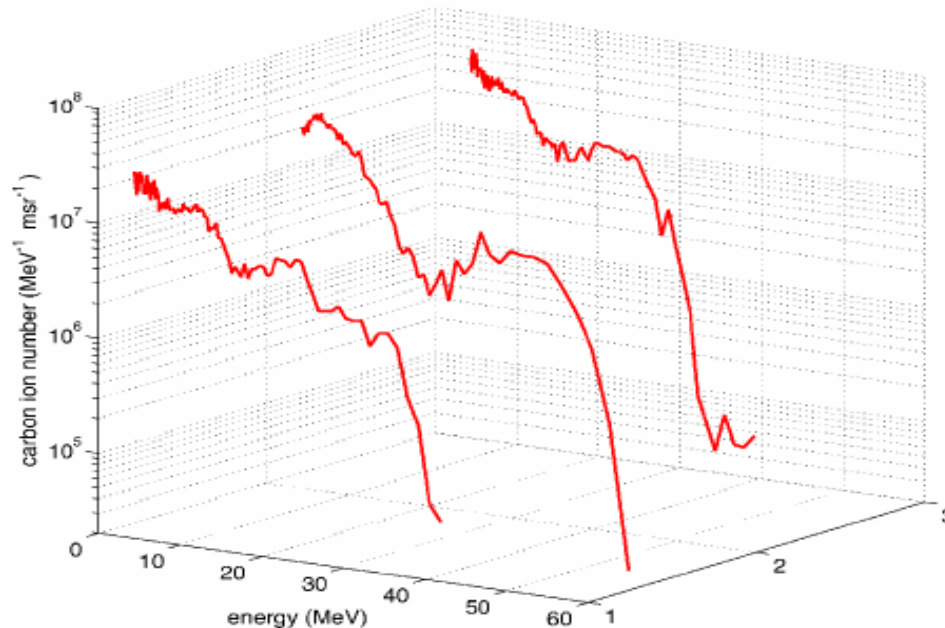

Carbon spectrum for three consecutive shots using circular polarized light at $5 \cdot 10^{19} \text{ W/cm}^2$ and a DLC foil target thickness of 5.9 nm

Coherent electron dynamics

Electron dynamics from thin foil: 3 clear patterns

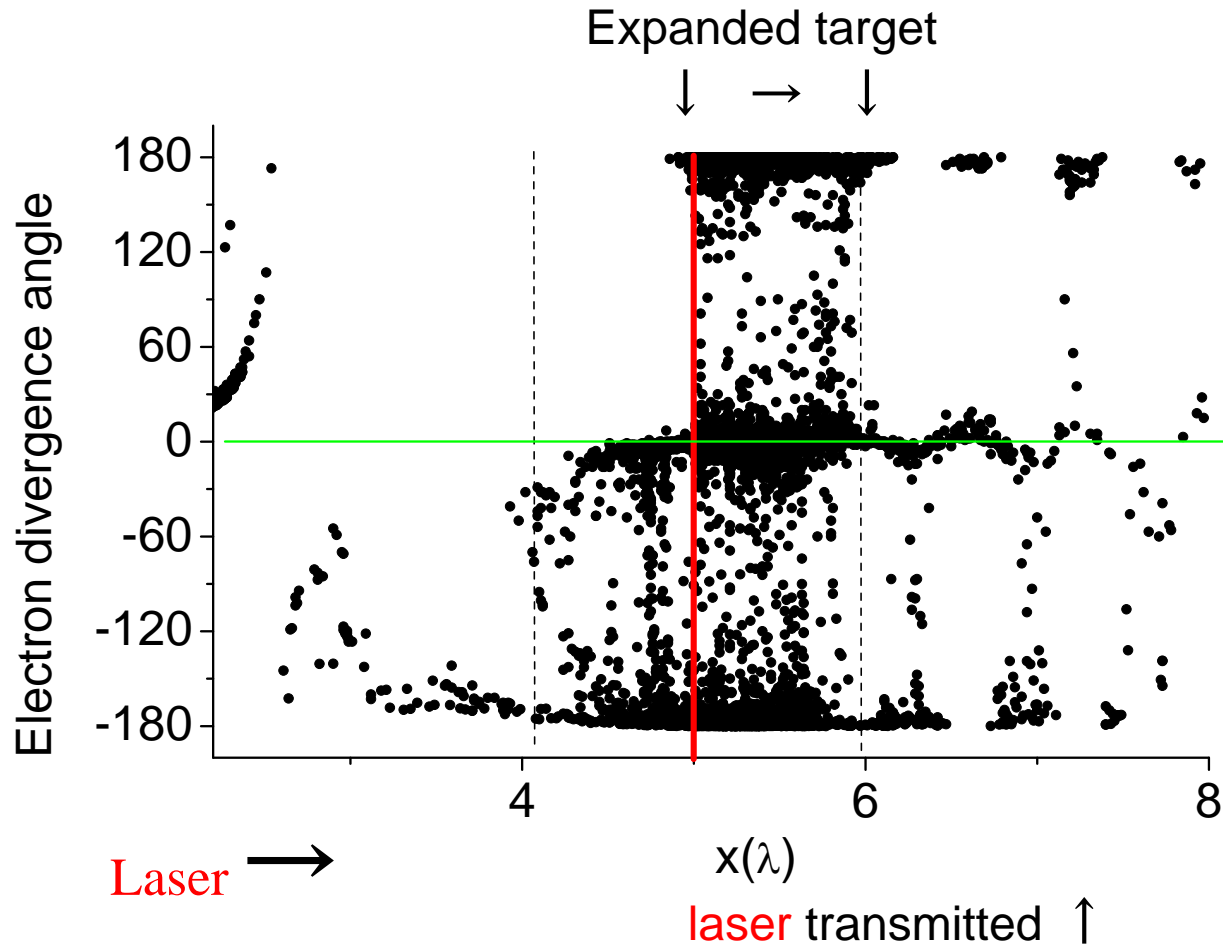

Characterization of coherent dynamics of electrons

LP

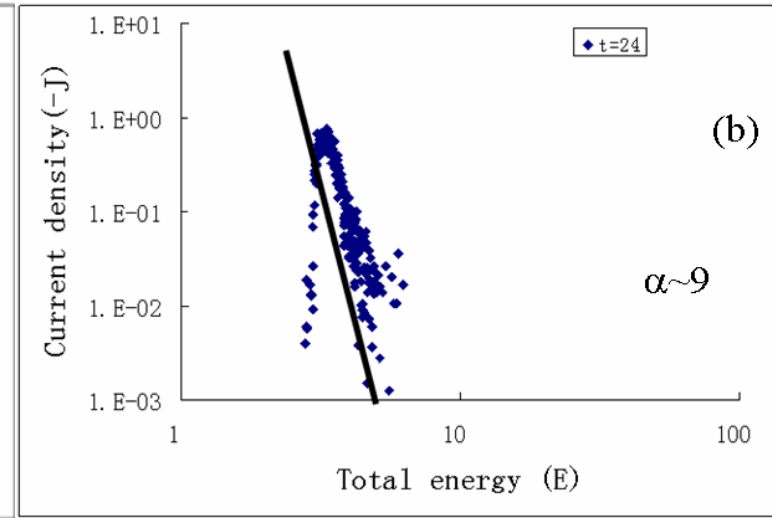
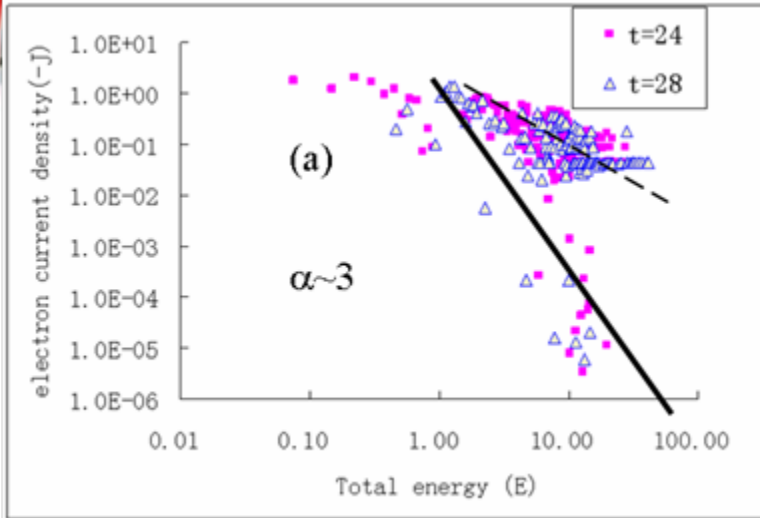

Coherence parameter: α

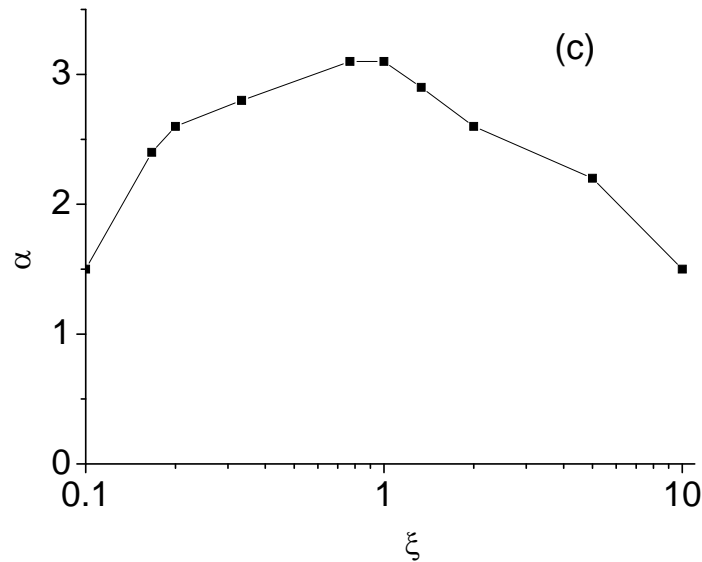

Dimensionless thickness parameter normalized to a_0

Energy Gain in Laser Ion acceleration: CAIL (Coherent Acceleration of Ions by Laser) regime

- When electron dynamics by laser drive is sufficiently coherent, with coherence parameter α of electrons, the ion energy in terms of electron energy is :

$$\varepsilon_{\max,i} = (2\alpha + 1) Q \varepsilon_0 \quad \text{Ion energy}$$

(the more coherent the electron motion, the higher the ion energy)

$$\varepsilon_0 = mc^2 \left(\sqrt{1 + a_0^2} - 1 \right) \quad \text{Electron energy = ponderomotive energy}$$

$$\varepsilon_{\max,i} = (2\alpha + 1) Q \bar{\varepsilon}_0(t_1) \left((1 + \omega_L t_1)^{1/2\alpha+1} - 1 \right)$$

α maximizes at $\xi = 1$

CAIL Theory Prediction

CAIL (Coherent Acceleration of Ions by Laser) theory has definitive prediction of max energies

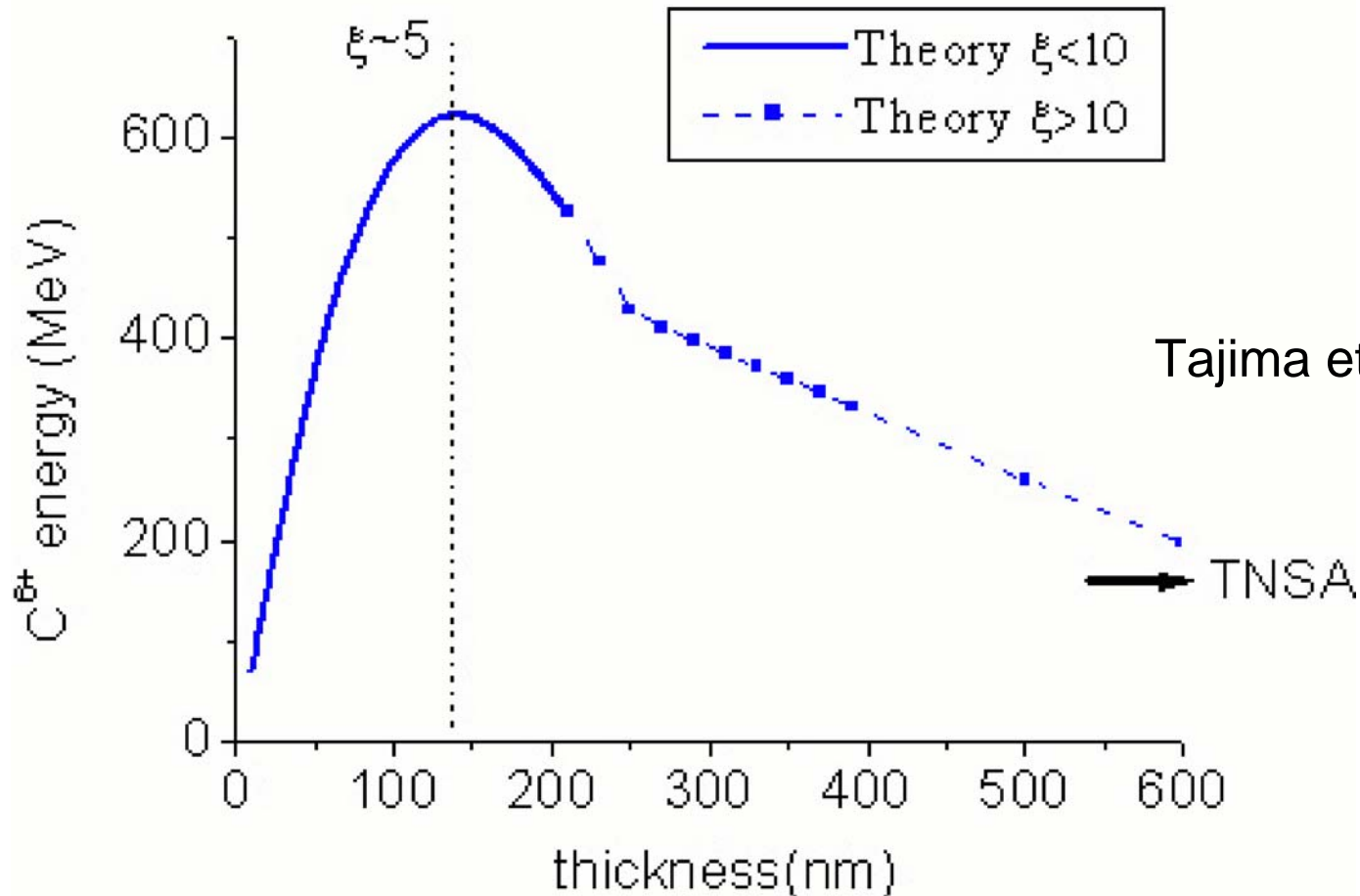

Tajima et al. (2009)

→ TNSA

For the case of LANL
 experiment prediction (relative long pulse with nm targets)

Ponderomotive Bucket Formation

Gradual dynamics
of the ponderomotive
bucket

Ponderomotive
Force \rightarrow
Electrostatic
Trapping of ions

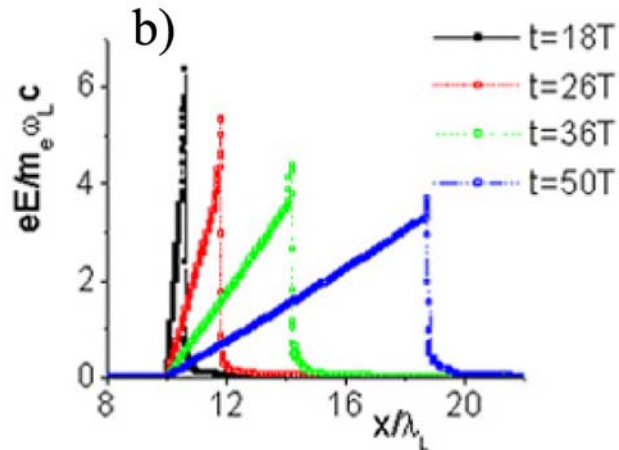
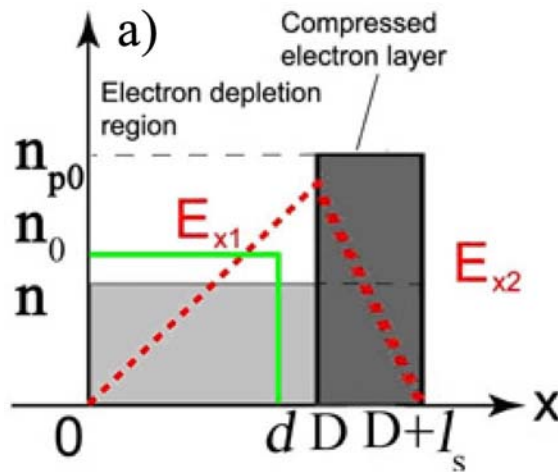

Yan et al. (2008)

Synchrotron oscillations in the bucket

Laser drives accelerating bucket,
more adiabatic **trapping structure**

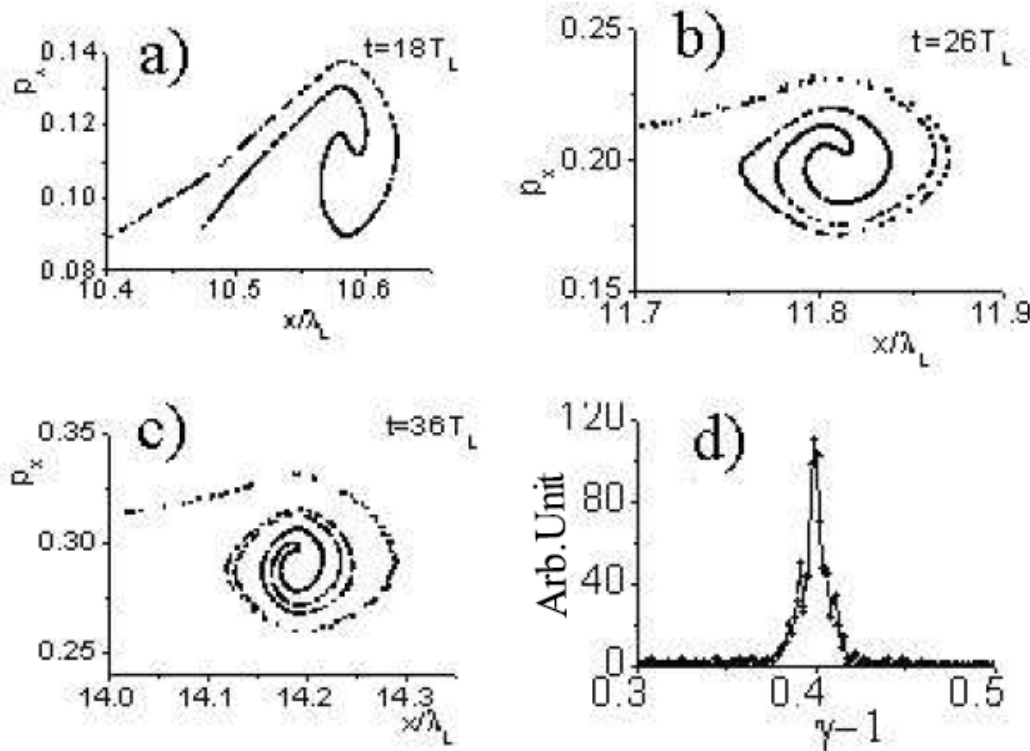

Yan et al.
(2008)

Monoenergy spectrum

(a,b,c) Evolution of phase space distribution for protons, the 1st, 2nd and 3rd oscillation period are 8, 8 and 10 T respectively.

(d) Energy spectrum of protons.

Circularly polarized laser driven

CP laser drives ions out of ultrathin (nm) foil **adiabatically**
Monoenergy peak emerges

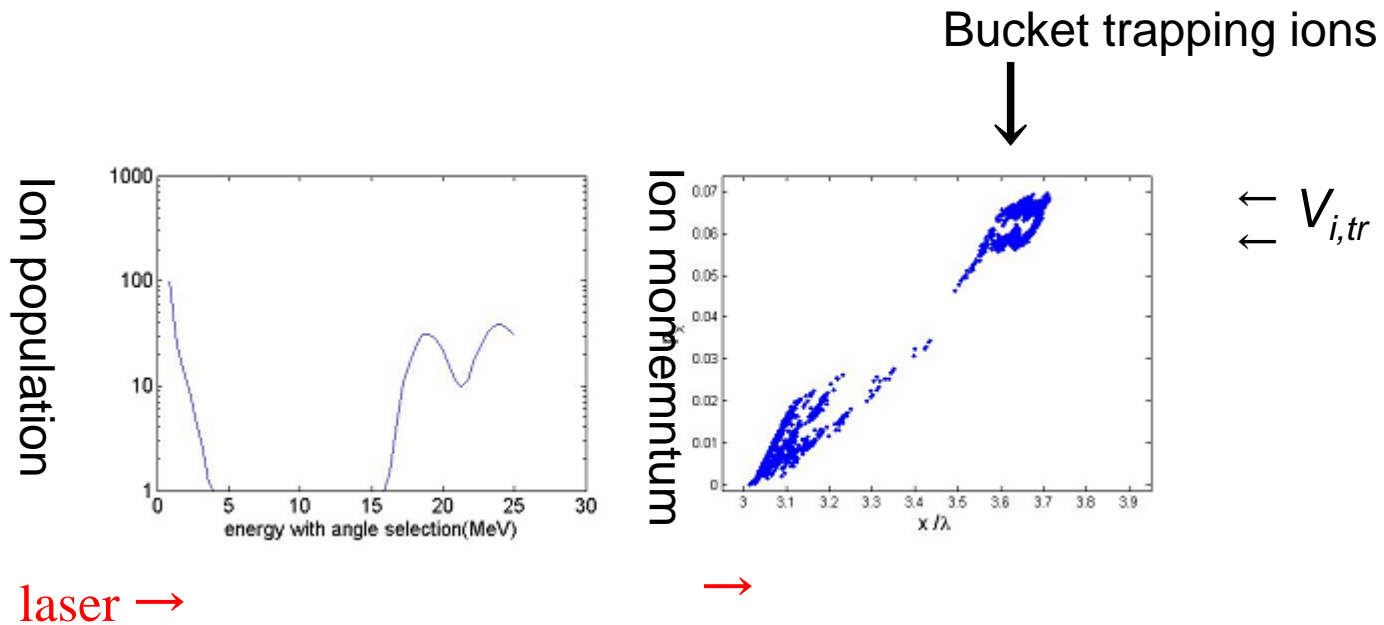

$$V_{i,tr} = c\sqrt{(a_0 m/M)}$$

(X. Yan et al: 2009)

Ponderomotive force drives electrons,
Electrostatic force nearly cancels
Slowly accelerating bucket formed

Phase space of carbon ions in 2D

Trapped in the bucket

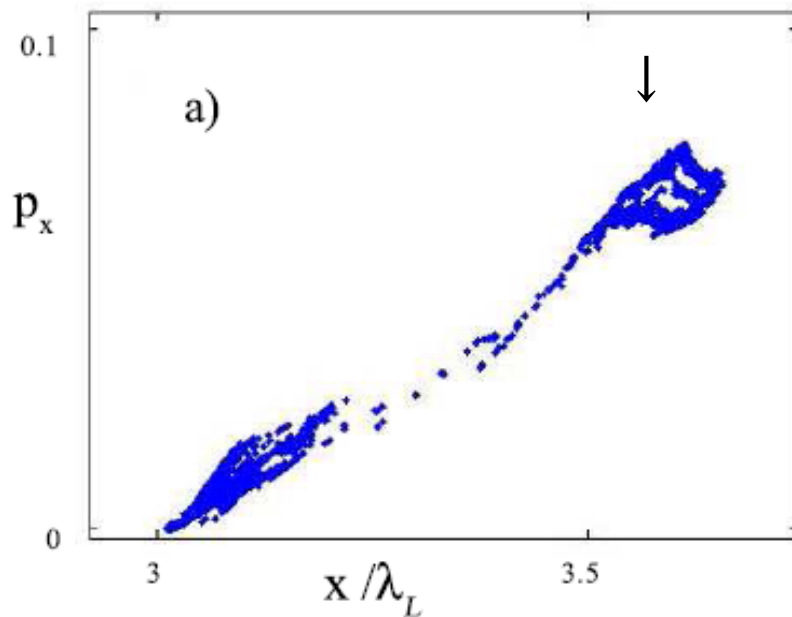

$t = 28 T_L$

Bucket **breaks down** by runaway e-

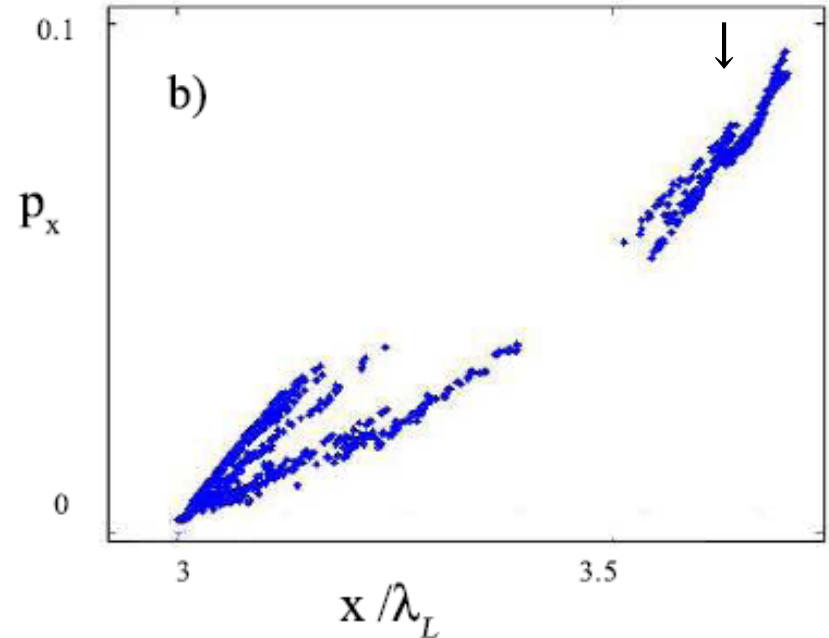

$t = 40 T_L$

Longitudinal phase space of carbon ions in 2D simulations. (a) Stable bucket structure of synchrotron oscillation; (b) Collapse of the accelerating bucket when the plasma becomes hot (due to the bending of the target)

Toward more adiabatic acceleration(4)

The more **adiabatic**, the longer accelerated, the higher energy

Energy by **CP** tends to increase as $\sim a_0^2$

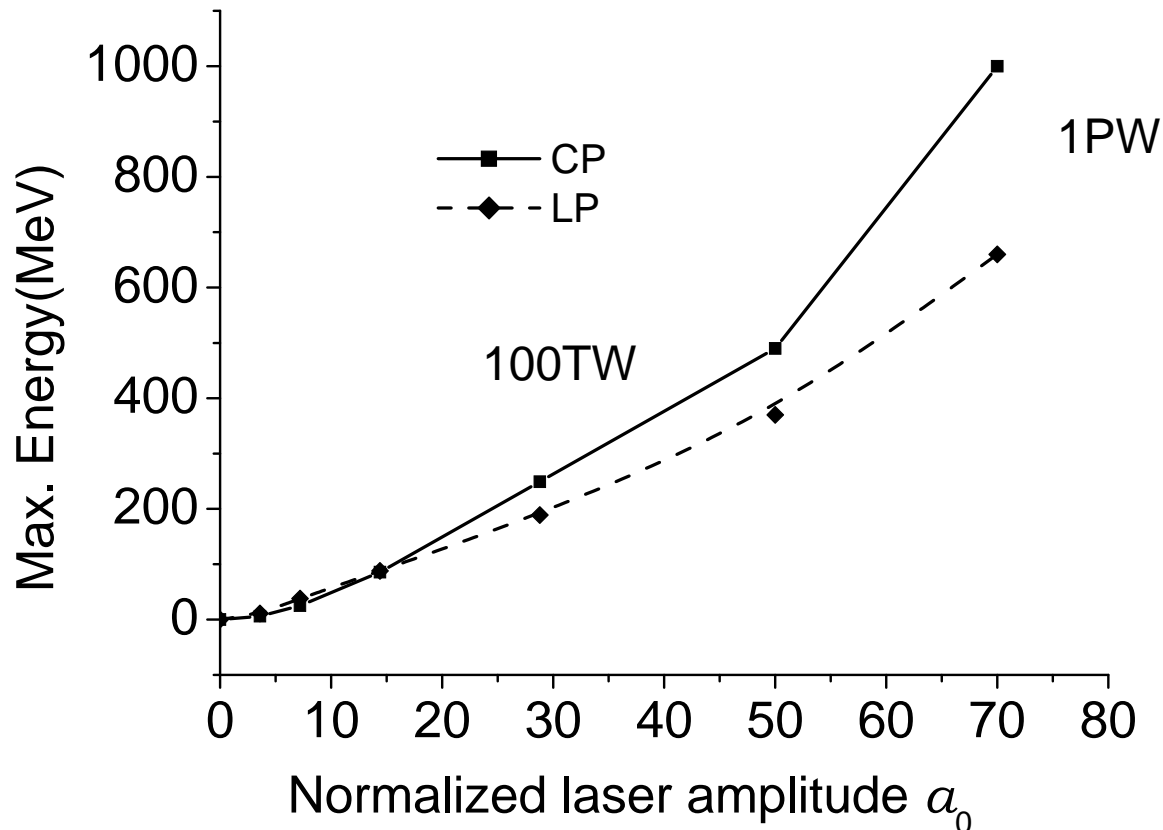

Monoenergetic electron bunch

Ultrathin (2nm) foil irradiation drives monoenergetic electrons
CP

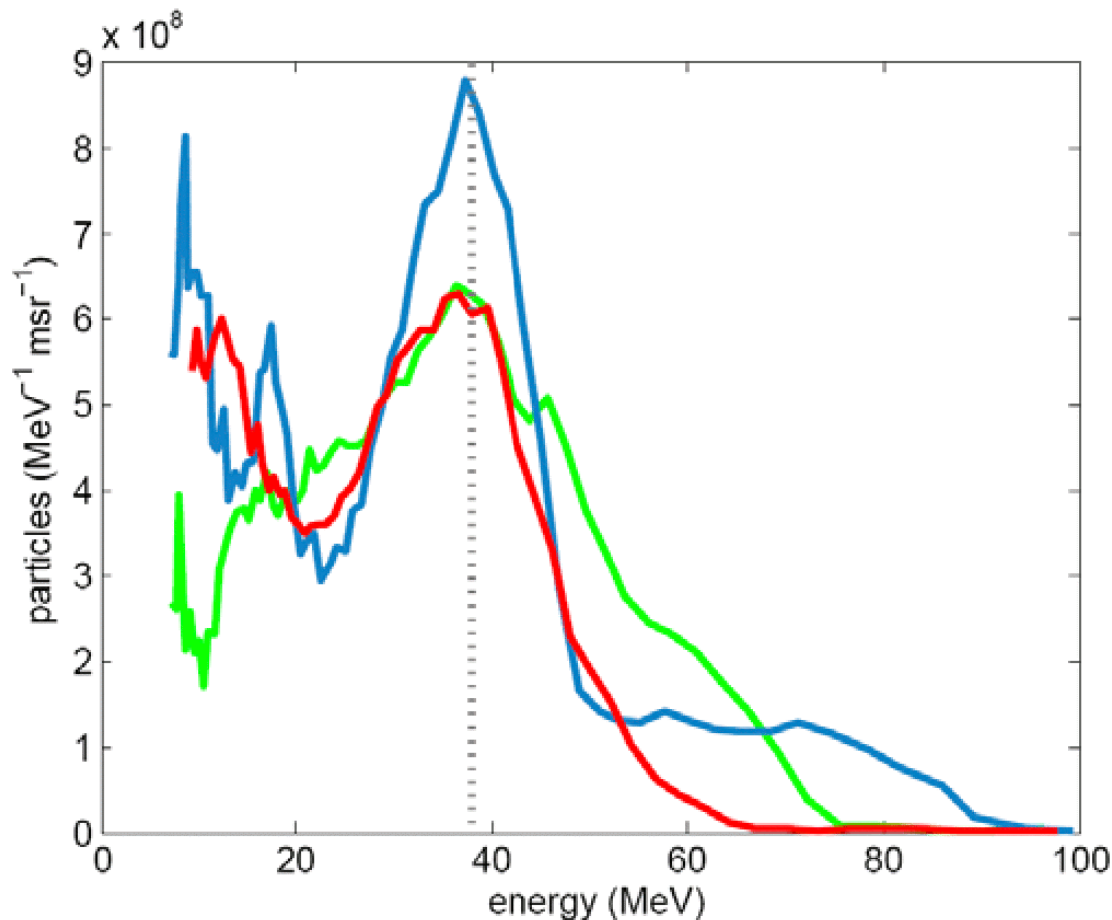

MAP + MBI

(Kiefer et al, 2009)

Adiabatic (Gradual) Acceleration

from #1 lesson of Mako-Tajima problem

Accelerating structure

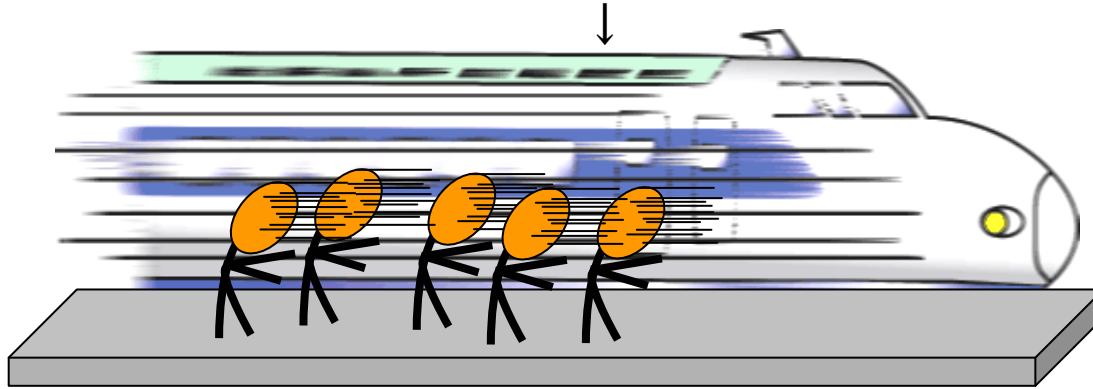

Inefficient if
suddenly
accelerated

protons ↑

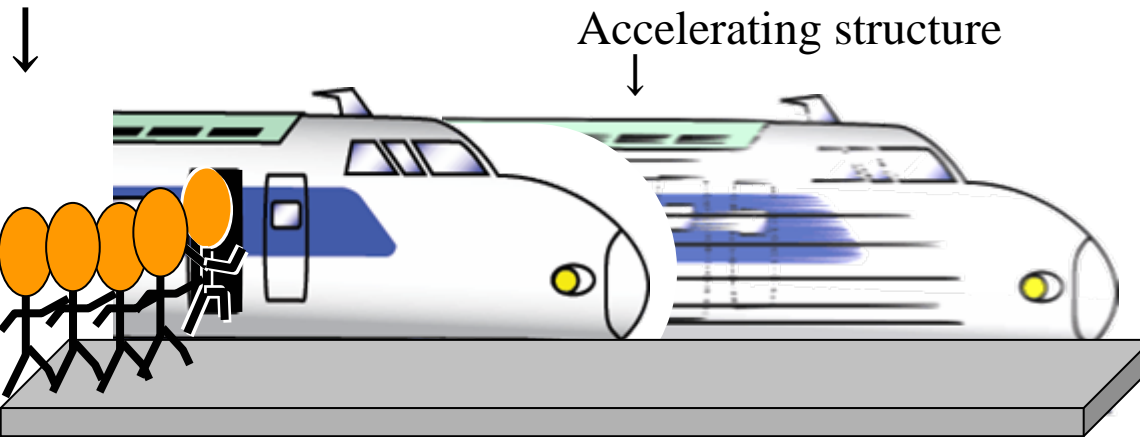

Accelerating structure

(cf. human trapping width:
 $v_{tr, human} \sim 1 \text{ m/s} \ll c_s$)

Efficient
when
gradually
accelerated

Lesson #1: gradual acceleration → Relevant for ions

Adiabatic acceleration (2)

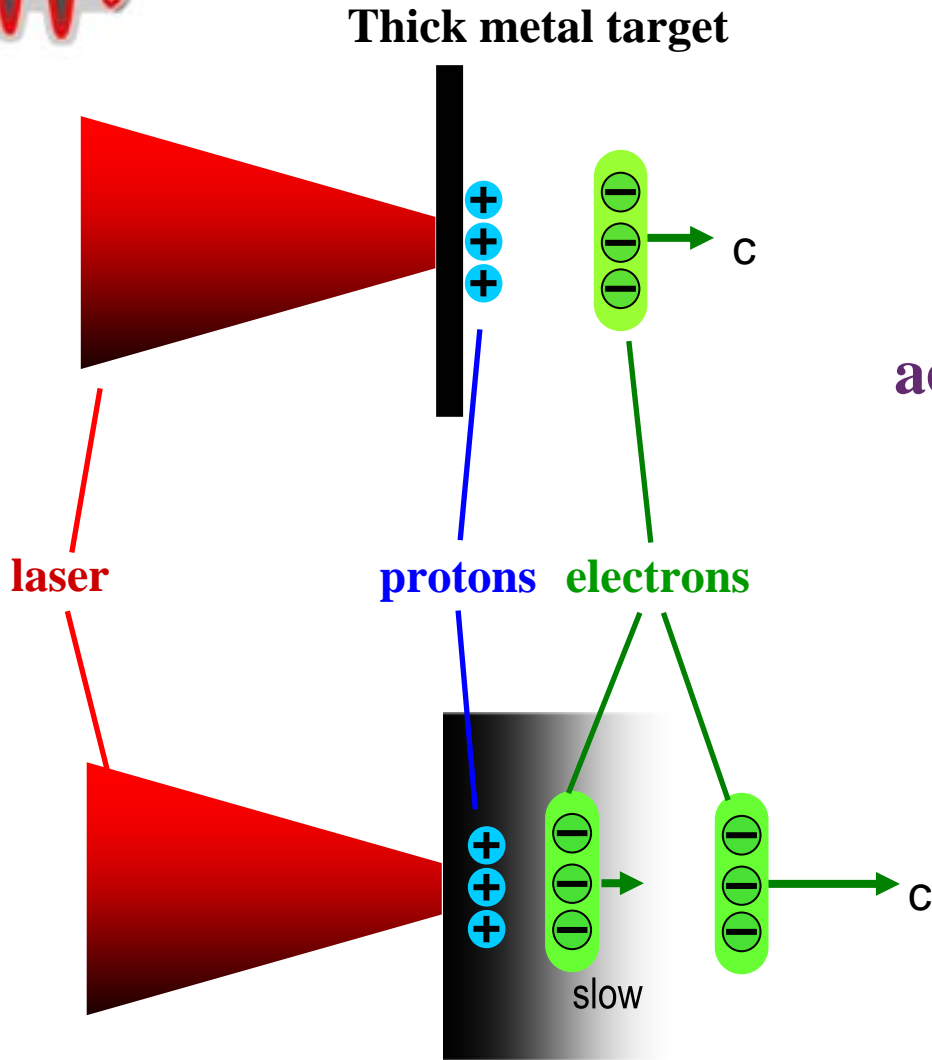

Most experimental configurations of proton acceleration (2000-2009)

Innovation (“Adiabatic Acceleration”)

(2009-)

= Method to make the electrons within ion trapping width

Graded, thin (nm), or clustered target and/or circular polarization

However, in **ELI** automatic

$$v_{tr, ion} \sim c \sqrt{a_0(m/M)} \sim c$$

(ultrarelativistic $a_0 \sim M/m$)

Laser Pulse Conditions

$$a_0 = \frac{\int n dl}{n_{cr} \lambda} = \frac{n l_{pl}}{n_{cr} \lambda}$$

$$a_0 = \frac{l_{las,||}}{\lambda}$$

$$l_{las,\perp} = \sqrt{\lambda R}$$

Adiabatic laser-plasma interaction

$$v_g(x) = c \frac{\sqrt{\omega^2 - \omega_{pe}^2(x)}}{\omega}$$

$$n(x) = n_0 \exp \left[-\pi \frac{m_e}{m_i} \frac{x}{\lambda} \left(\frac{R}{\lambda} \right)^{1/2} \right]$$

(Tajima, Bulanov, Esirkepov, 2007)

Relativity Helps Acceleration (for Ions, too!)

Extreme Field Science



The National Ignition Facility

Ultra-relativistic Regime:
charged particles move with photons

Electron Energy in strong field

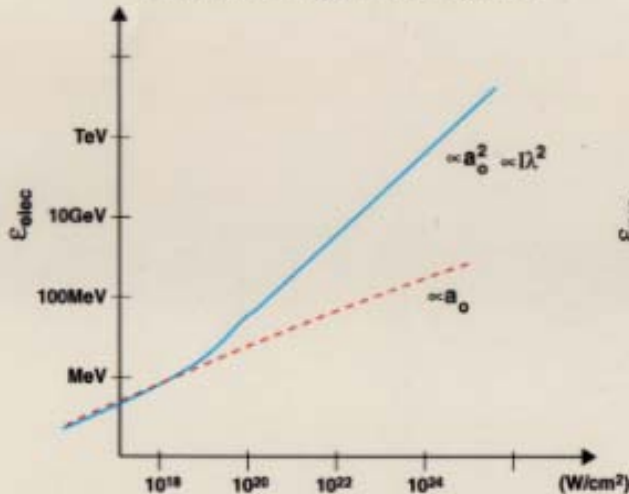

Proton Energy from Debye sheath in strong field

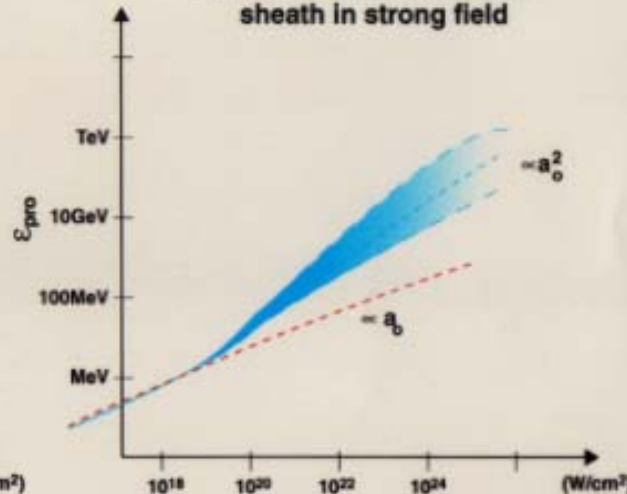

Intensity of laser (a_0^2)

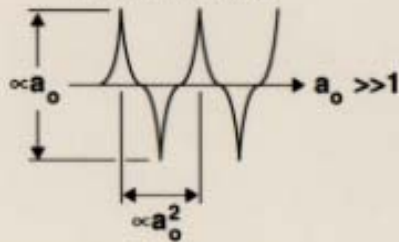

$$a_0 \sim 1.5 \left(\frac{\lambda}{1 \mu\text{m}} \right) \left(\frac{I}{10^{20} \text{ W/cm}^2} \right)$$

Strong fields:
rectifies laser
to longitudinal
fields

In relativistic regime,
photon x electrons
and even protons
couple **stronger**.

(Tajima, 1999
@LLNL;
Esirkepov et al.,
PRL,2004)

Monoenergy beam from double layer target

Double layer target (metal layer with smaller hydrogen (or light Z material))

laser

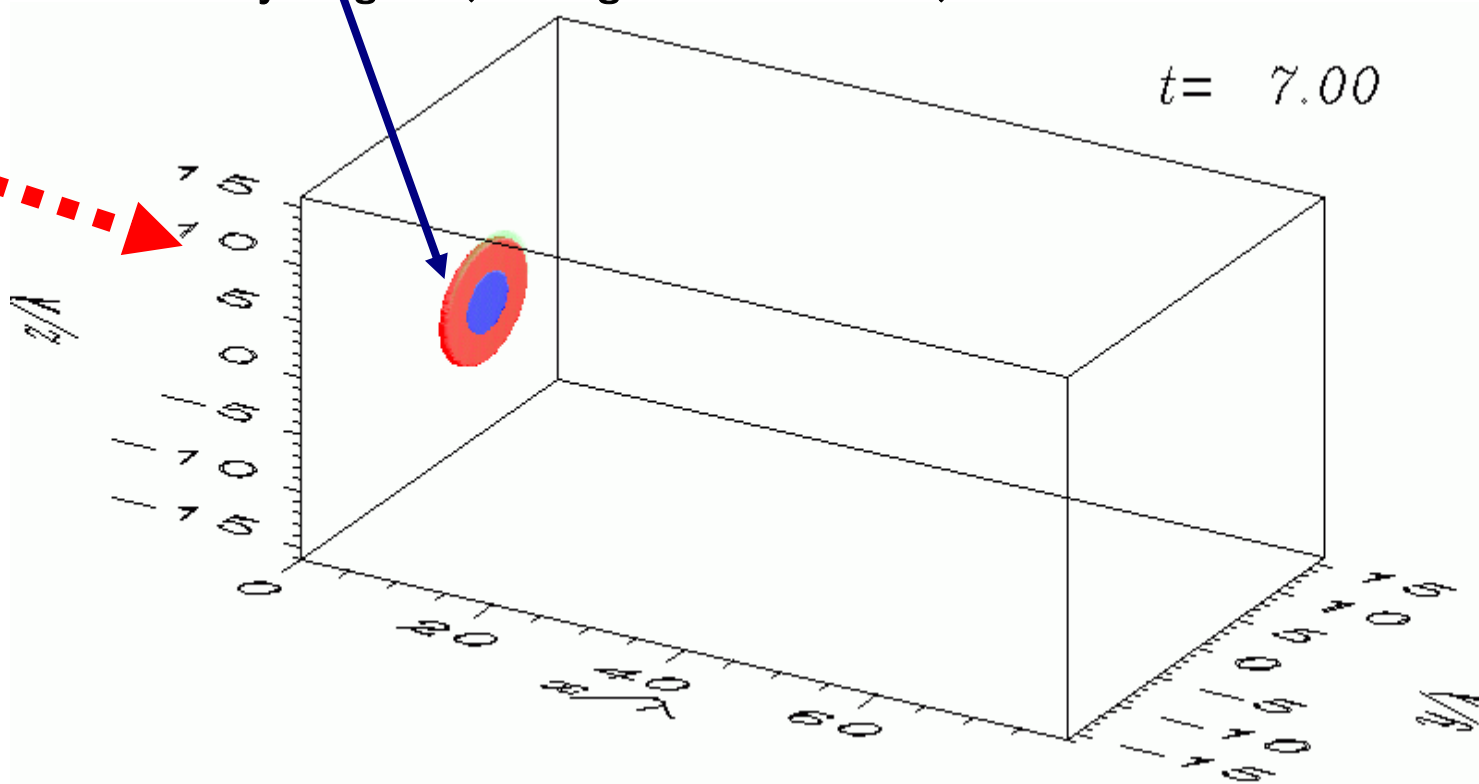

Esirkepov et al.(2002)

Laser Piston (radiation pressure) Acceleration

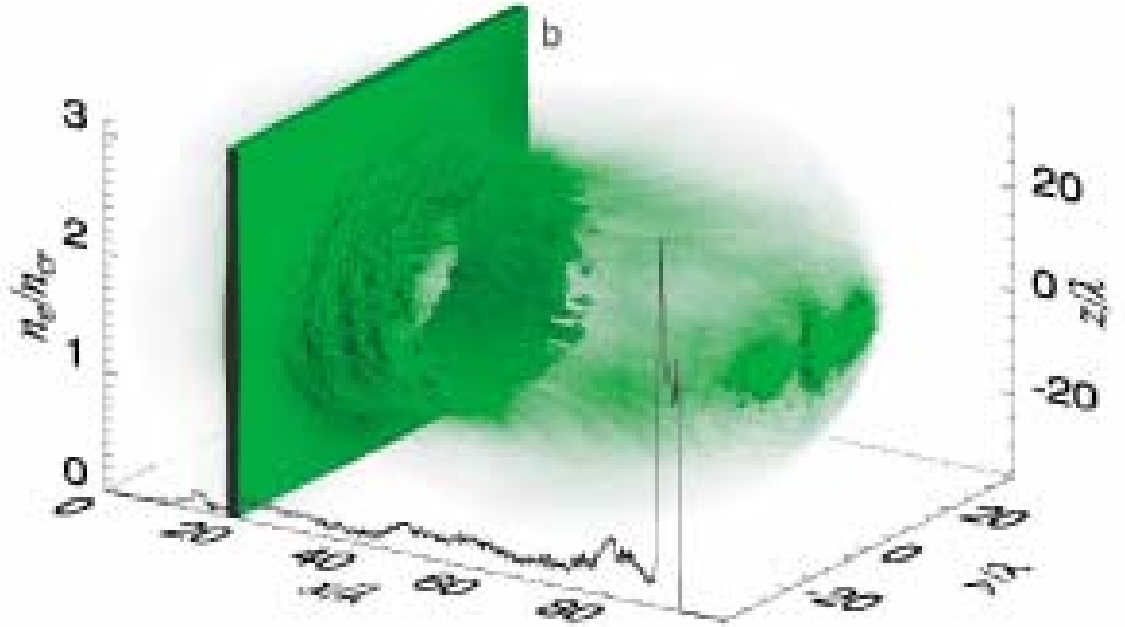
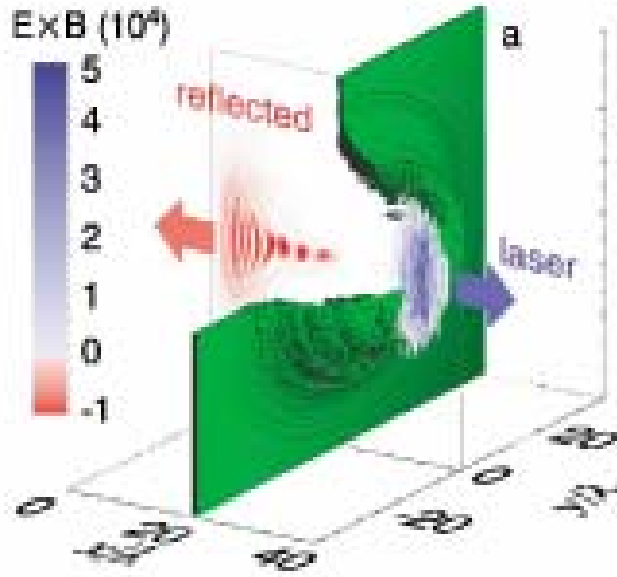

Radiation dominant regime

Esirkepov et al. (2004)

Nanostructured target

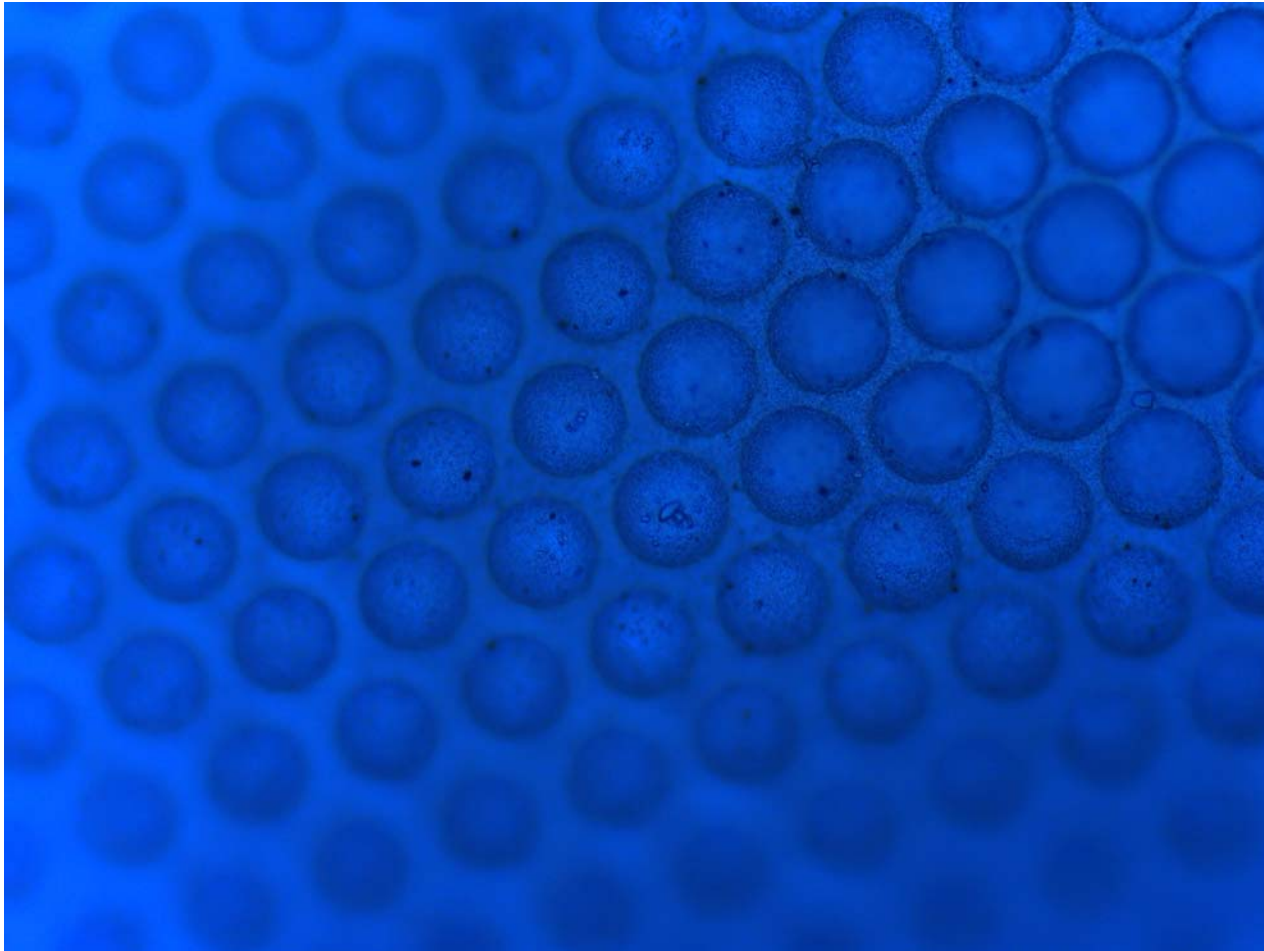
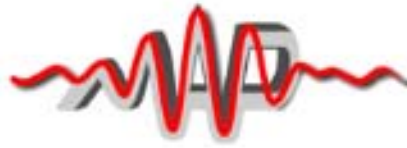

(Habs, 2009)

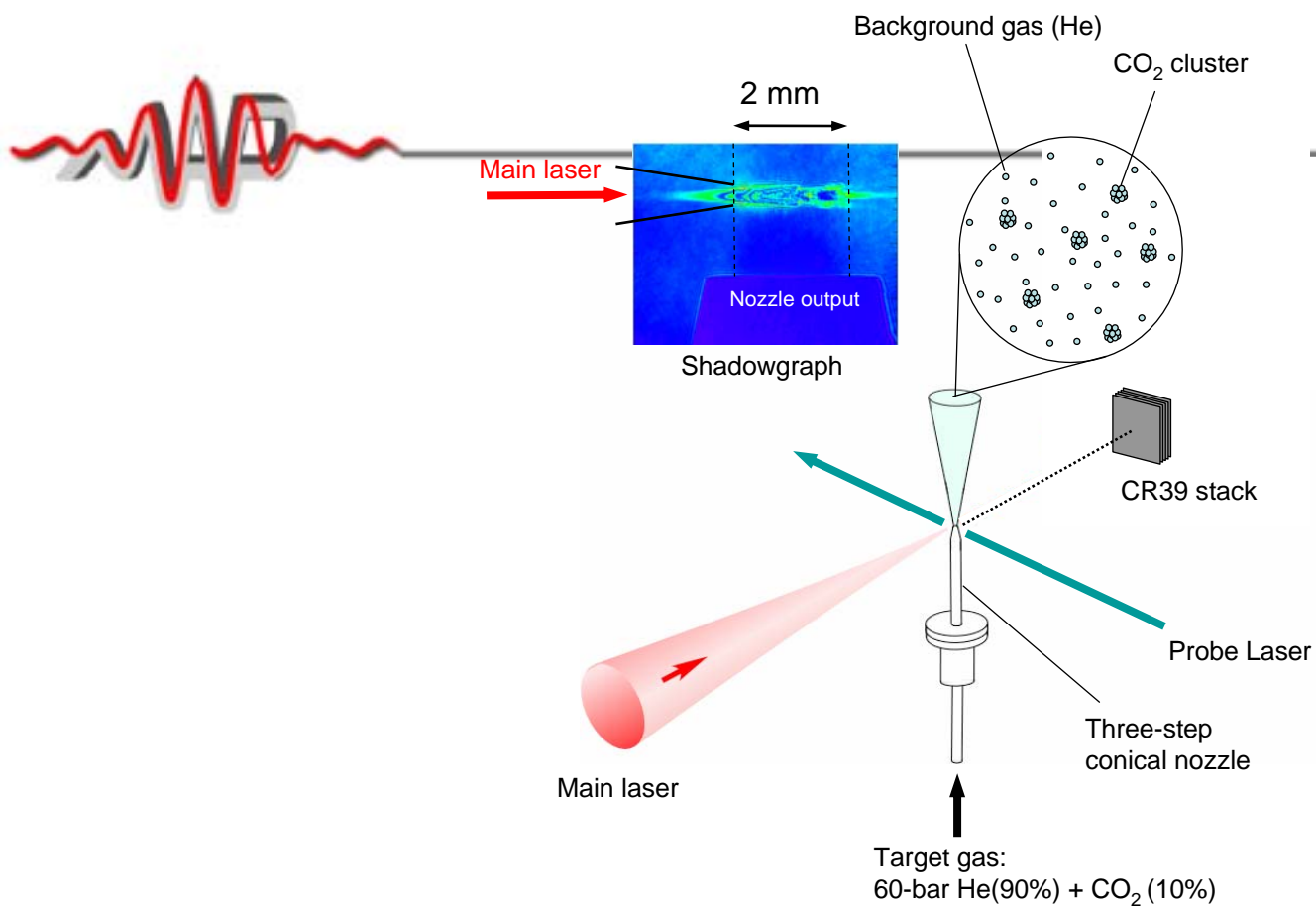

Cluster Target Irradiation

Y. Fukuda et al. (2009)

Order of magnitude energy gain

With a modest (140mJ) laser, to go beyond 15MeV/nucleon by cluster target

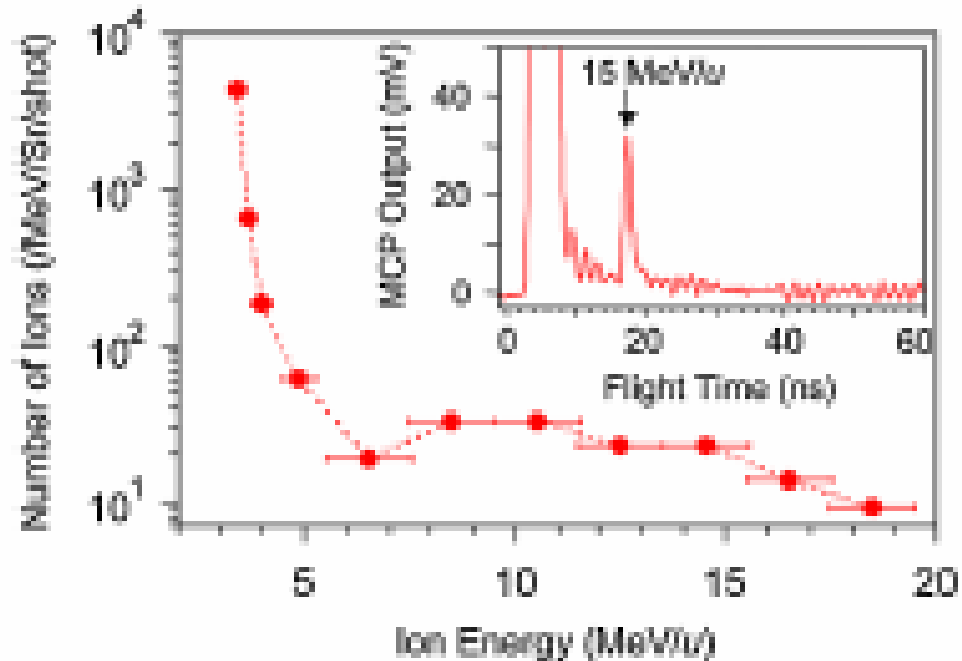
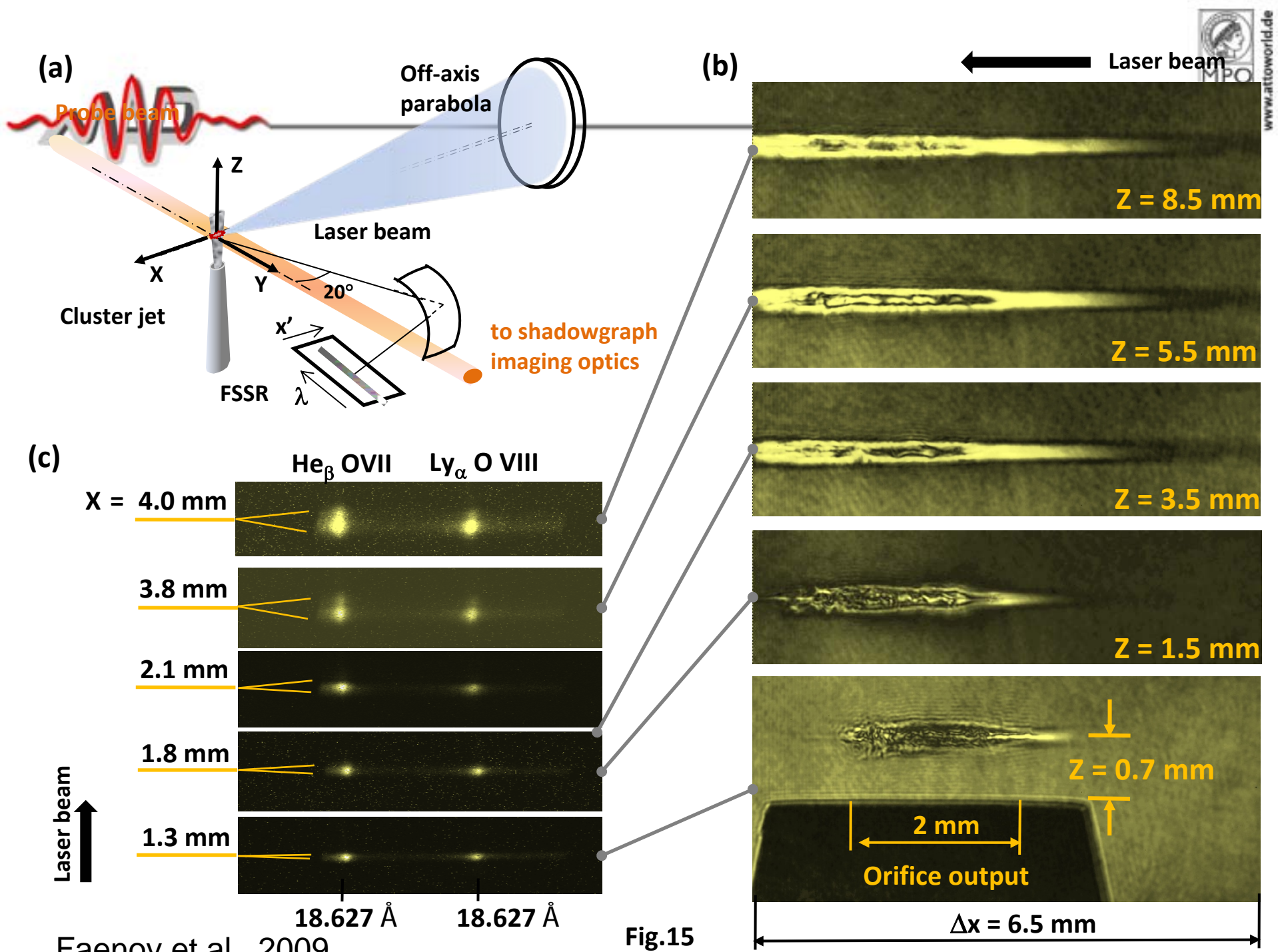
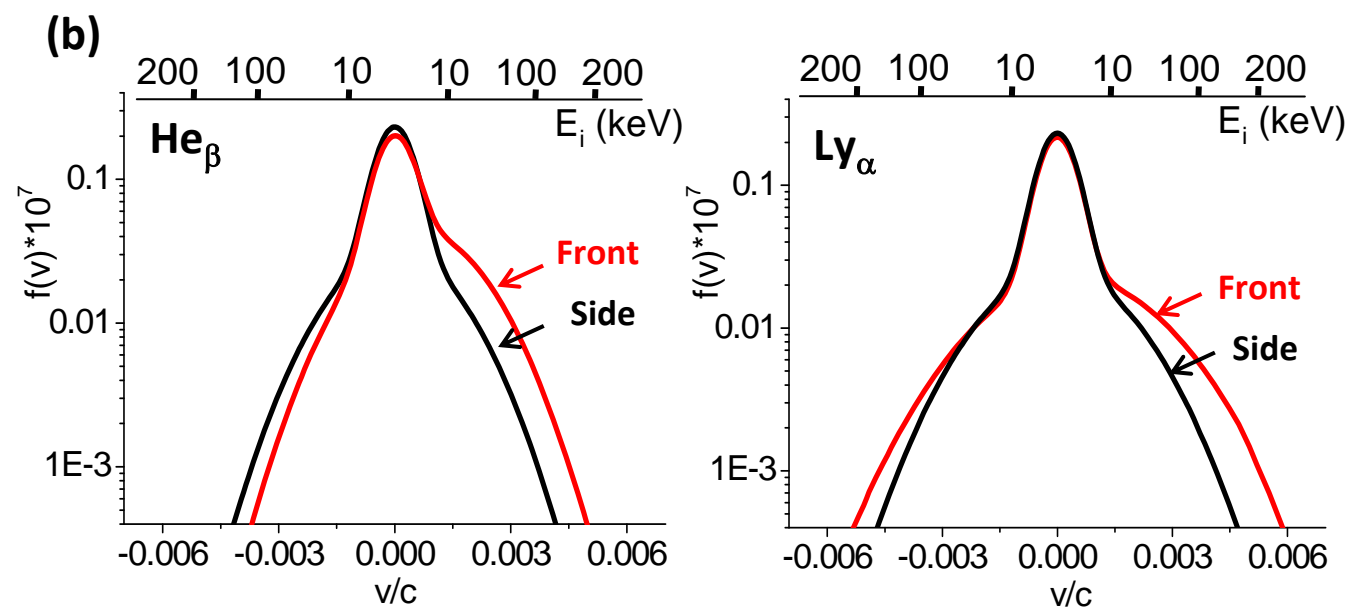
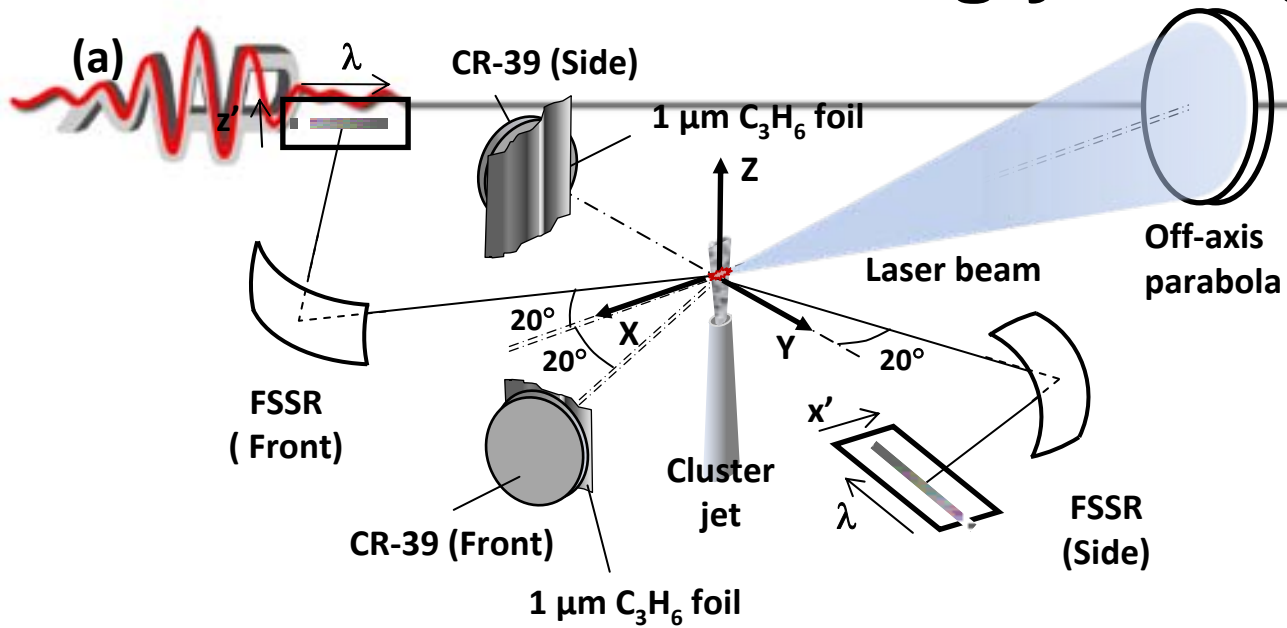

FIG. 3 (color online). The ion energy spectrum obtained by the TOF method. The inset shows TOF spectrum obtained in one laser shot which registers 15 MeV/u ion signal. A saturated signal around the flight time $t = 5$ is caused by hard x rays emitted from the laser-cluster interaction region.



Cluster ions strongly energized



Faenov et al.,
2009

Fig.11

Laser-carbon cluster interaction

$a_0=4$

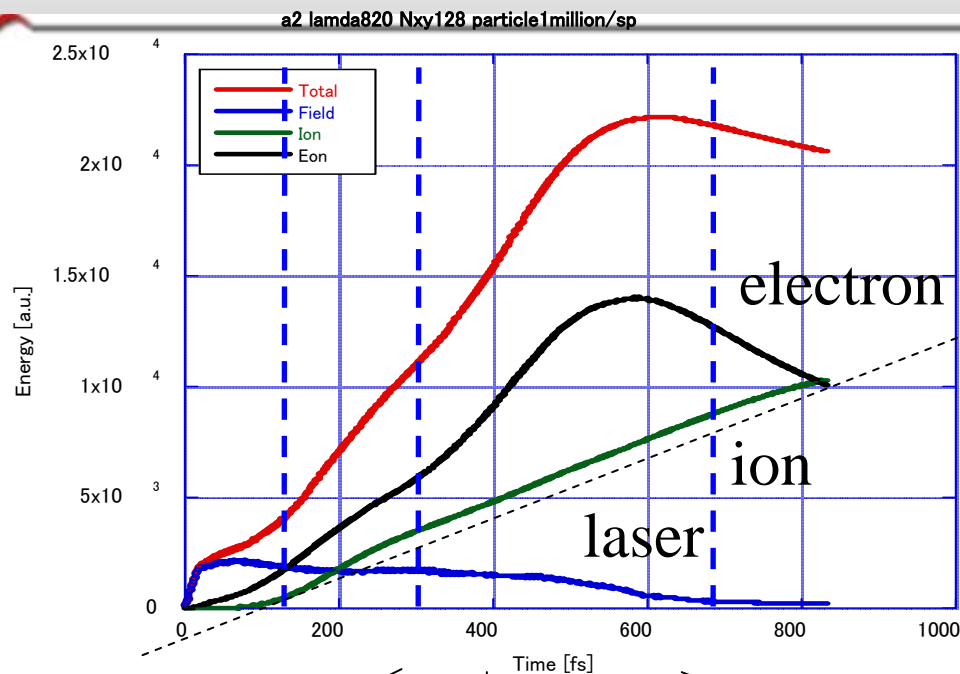

Ion energy
~ pulse length
(laser energy)

Kishimoto (2009)

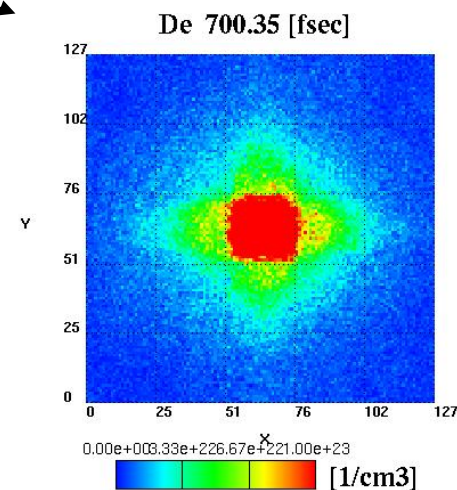
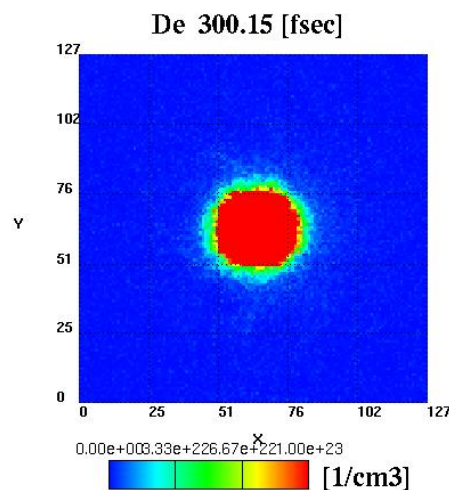
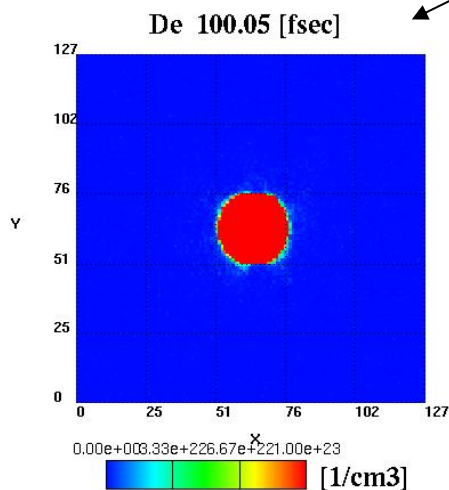

Maximum energy vs. laser intensity

Cluster target scaling

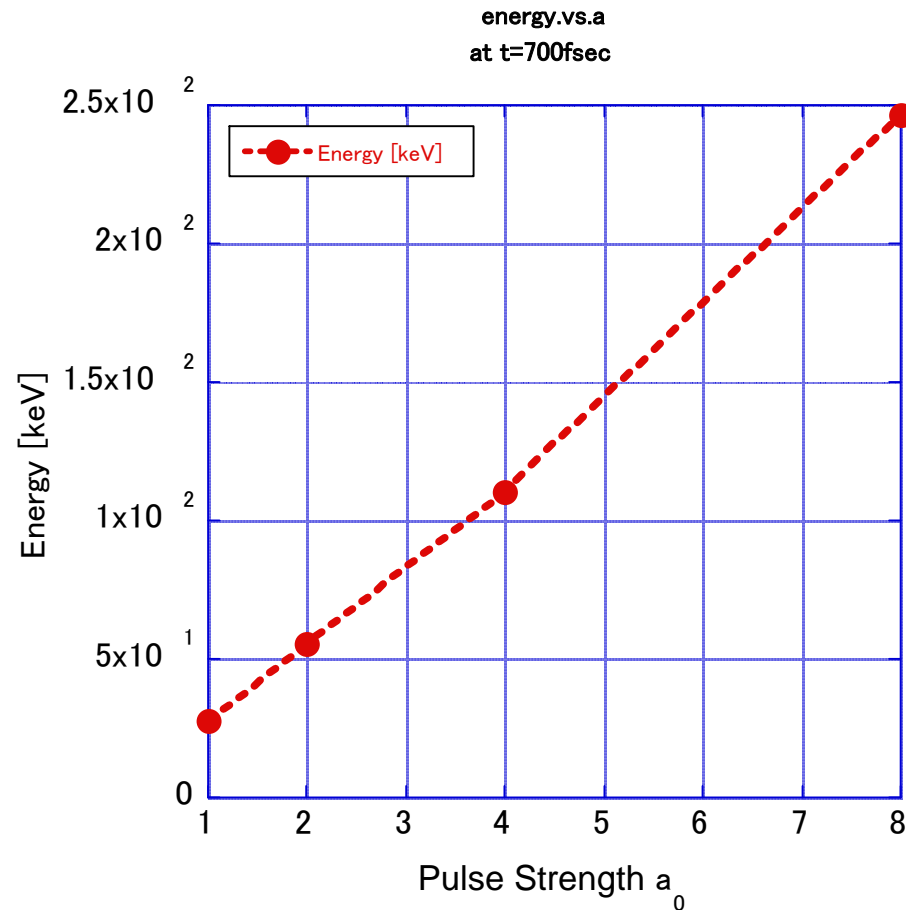

Consistent to the Theory by Yan et al. (2009), though it is based on thin film case

$$\varepsilon_{\max} = (2\alpha + 1)Q\sqrt{1 + a_0^2}$$

Ion Energy spectrum $r=125 \mu\text{m}$

Ion Energy Distribution
fEilog_a4_I820_Nxy128_p1m_r125nm
Energy [keV]

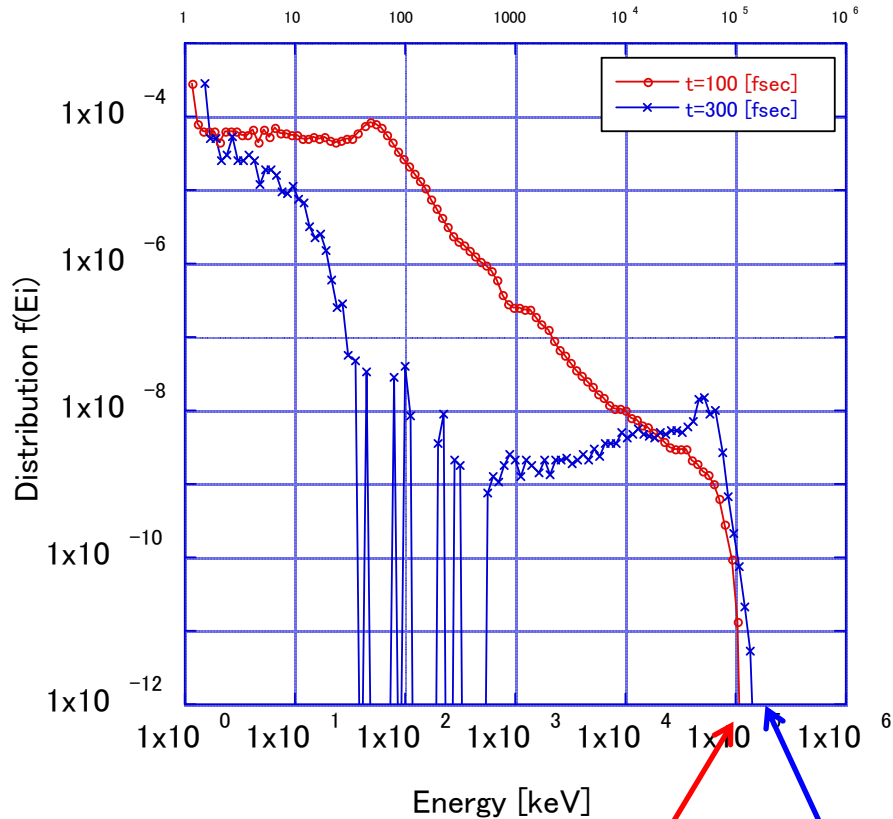

114.9MeV 150.98MeV

Ion Energy Distribution
fEilog_a4_I820_Nxy128_p1m
Energy [keV]

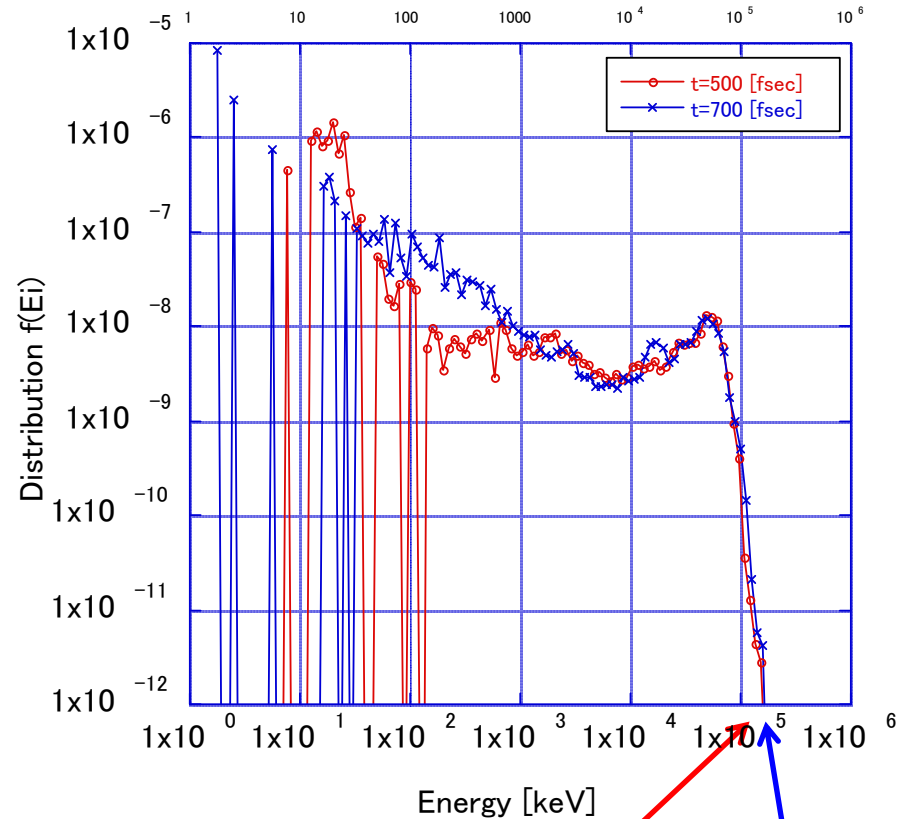

171.71MeV 178.84MeV

Ion Energy vs. Cluster Radius

Cluster target scaling: ion energy \sim $1/(\text{cluster radius})$

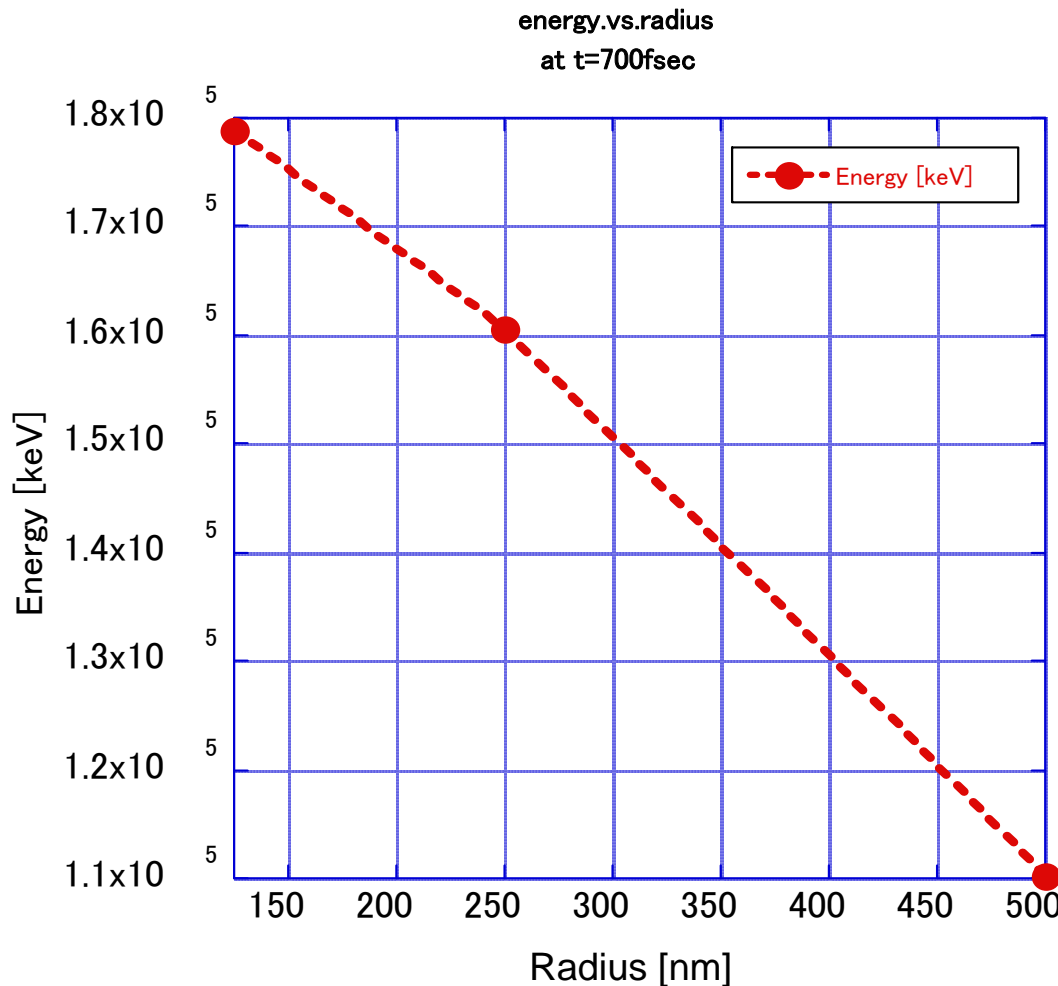

Kishimoto, Tajima
(2009)

Toward Compact Laser-Driven Ion Therapy

PET or γ ray image of autoradioactivation

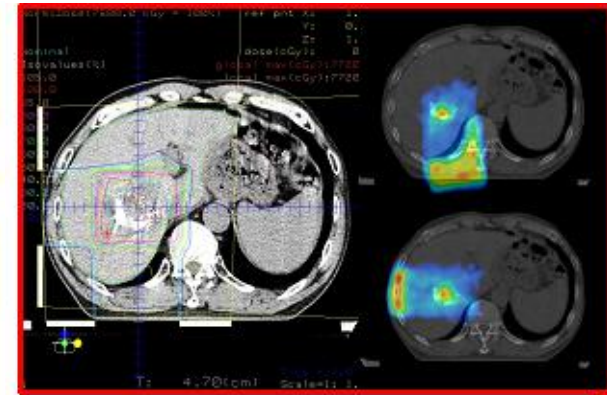
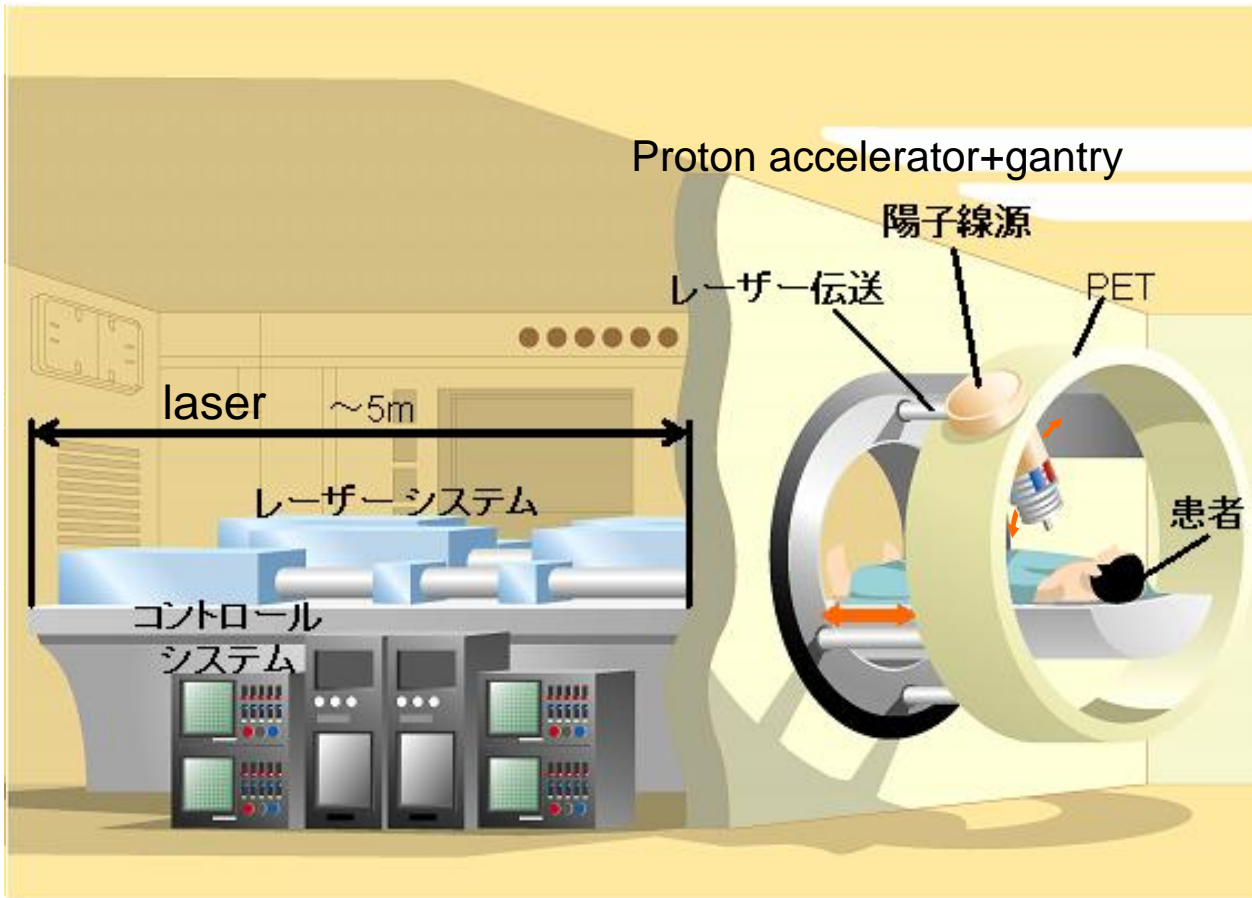

治療計画(診断と照射)

Laser particle therapy (image-guided diagnosis → irradiation → dose verification)
targeting at smaller pre-metastasis tumors with more accuracy

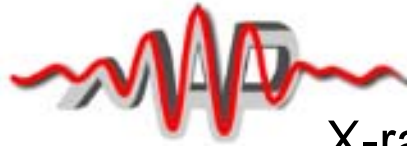

X-ray IMRT

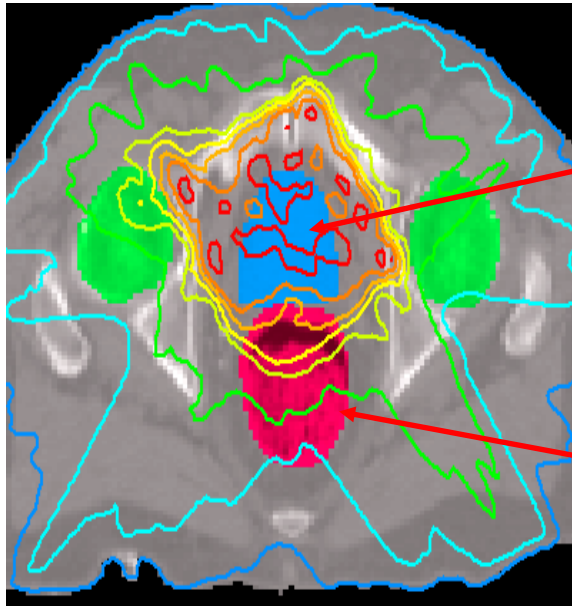

prostate cancer
rectum

Proton IMRT

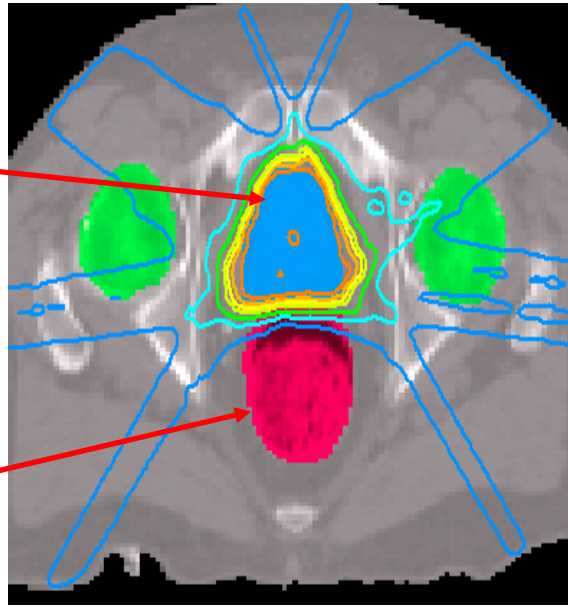

January 20, 2010: “Relativistic Engineering”
 February: “High Field Science”
 March: “Photonuclear Physics”
 April: “Medical Applications”

.....

Merci Beaucoup et a la Prochaine Fois!